

The background is a vibrant red field decorated with abstract geometric shapes. In the top-left corner, there is a green quarter-circle and a blue semi-circle. The top-right features a blue semi-circle with a white circle inside, and a dark blue horizontal bar. The bottom-left has a blue semi-circle with a white circle inside, and a dark blue semi-circle below it. The bottom-right is dominated by a large green semi-circle and a red semi-circle with a white border. The text is positioned in the upper-left quadrant of the red field.

Appendix K
Drainage Design Basis

NTA

BusConnects Core Bus Corridor

Drainage Design Basis

BCIDX_ARP-PMG_PS-0000_XX_00-SD-ZZ-0002

Final | 14 January 2022

This report takes into account the particular instructions and requirements of our client.

It is not intended for and should not be relied upon by any third party and no responsibility is undertaken to any third party.

Job number 268401

Ove Arup & Partners Ireland Ltd

Arup
50 Ringsend Road
Dublin 4
D04 T6X0
Ireland
www.arup.com

ARUP

Contents

	Page
1 Introduction	1
1.1 Background and Overview of the Project	1
1.2 General principles of drainage design	1
1.3 Method of design	3
2 Proposed drainage strategy	5
2.1 Relevant Standards and Guidance	5
2.2 Storm Water Management	7
2.3 Sustainable Drainage Systems (SuDS)	7
2.4 Pipe Materials	7
2.5 Distance between manholes	8
2.6 Clash Checks	8
2.7 Bedding Haunching and Surround	8
2.8 CBC design criteria	9
2.9 Gullies	11

Appendices

Appendix A

SuDS Eligibility

Appendix B

Bus Connects – Road run-off collection gullies

1 Introduction

1.1 Background and Overview of the Project

This document has been prepared by the BusConnects Infrastructure Works Team.

The aim of the BusConnects programme is to transform Dublin's bus system, with the Core Bus Corridor (CBC) project aiming to provide 230kms of dedicated bus lanes and 200km of cycle lanes on sixteen of the busiest bus corridors in and out of the city centre. This project is fundamental to addressing the congestion issues in the Dublin region with the population due to grow by 25% by 2040, bringing it to almost 1.55m.

The CBC project will aim to implement an optimum project cross-section to include footpaths, cycle tracks and bus lanes on both sides of the road throughout the CBC network where feasible (see Figure 1). In some instances, this will necessitate a Compulsory Purchase Order (CPO) process to include portions of private land to achieve the project objectives.

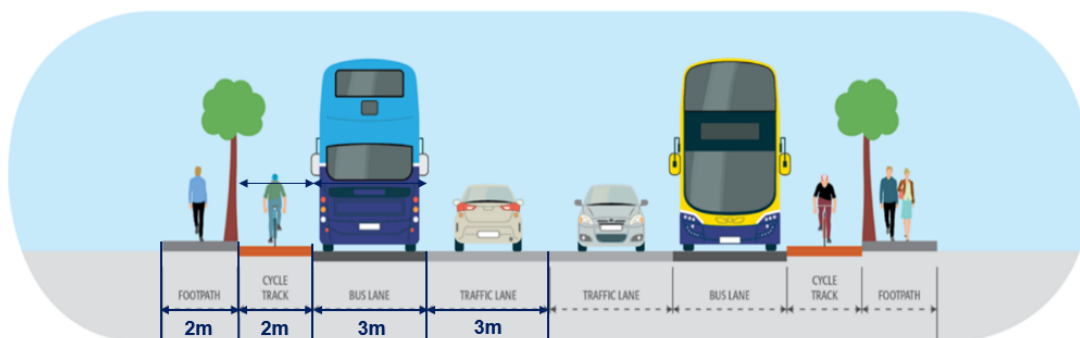

Figure 1: Optimum Typical CBC Cross-Section

1.2 General principles of drainage design

- The existing drainage network will be maintained and used as the main discharge point for the new drainage system. The idea of the design will be replicating the existing situation. Where new multiple gully connections discharging to a combine sewer are required, a new surface water pipe will be provided where possible and connected to the combine sewer as per Irish Water requirements.
- All drainage structures should be designed with a minimum return period of no flooding in 1:30 years. A climate change allowance of 20% will be added to all rainfall depths.
- Sustainable Urban Drainage Systems (SuDS) requirements. A SuDS drainage design will be developed as a first preference and in accordance with the SuDS hierarchy. Please refer to Appendix A: Drainage Design Criteria - SuDS Eligibility of the current document.

- At planning stage the design will be developed on the basis of existing drainage records, site visits, google earth and some specific targeted surveys if required. If available, additional information from DCC or Irish Water will be reviewed and considered where relevant.
- Physical drainage investigations might be required at detailed design stage to determine precise details of existing drainage along the route, the size, number, depth, and location etc. of each drainage infrastructure present along the route.
- At Planning Stage infiltration rates have not been considered within the calculations. The use of measures such as bioswales or tree pits will be promoted where appropriate. Permeability tests will be completed at detailed design so that infiltration rates can be considered in the calculations during detailed design stage.
- The design will be based on avoiding increasing the discharge flow to an existing network. An assessment of the necessity of possible attenuation to restrict the flow rates to the current conditions should be developed at planning stage. This assessment is further explained in Section 2.8. The attenuation facilities will be provided in the shape of SuDS. Where spatial or other constraints make the use of SuDS not feasible or not possible or when SuDS do not provide enough attenuation, oversized pipes will be required.
- While the scheme will involve an increased paved area it is envisaged that with Bus Connects in operation and better connectivity, a better public transport system will further reduce traffic on the existing routes thus reducing risk of pollution for the current situation. Where reasonably possible for additional catchment areas, SuDS elements, such as bio-swales or tree-pits will be implemented. This way, runoff will flow through porous layers that will provide a level of treatment (and attenuation) before discharging into the existing network. Please refer to Appendix A for further details. Where SuDS are not possible or feasible all run-off from paved areas are proposed to be collected in a positive drainage system, and not be discharged over the edge of embankments. Spillways are not therefore proposed.
- Narrow filter drains or fin drains are not expected for inner city roads. An assessment of the provision of subgrade drainage will be developed where necessary.
- Existing drainage gullies located in the bus lane or cycle track should be removed when necessary and reused where possible. Side-entry kerb drainage/side-entry gullies should be considered for all new kerblines that must accommodate rainwater run-off. Existing gully connections will be used where possible. The drainage design will ensure that additional ponding does not occur along the routes.

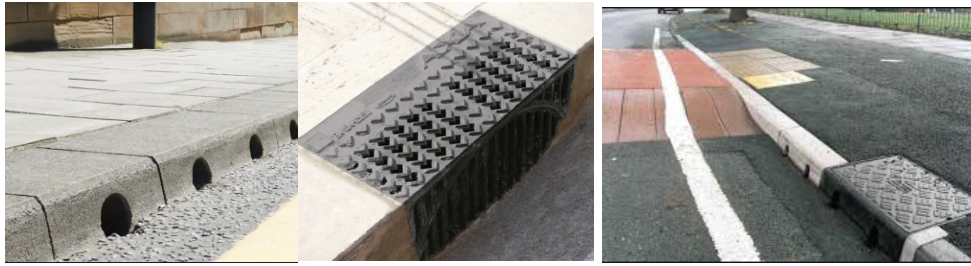

Figure 2: Side gullies

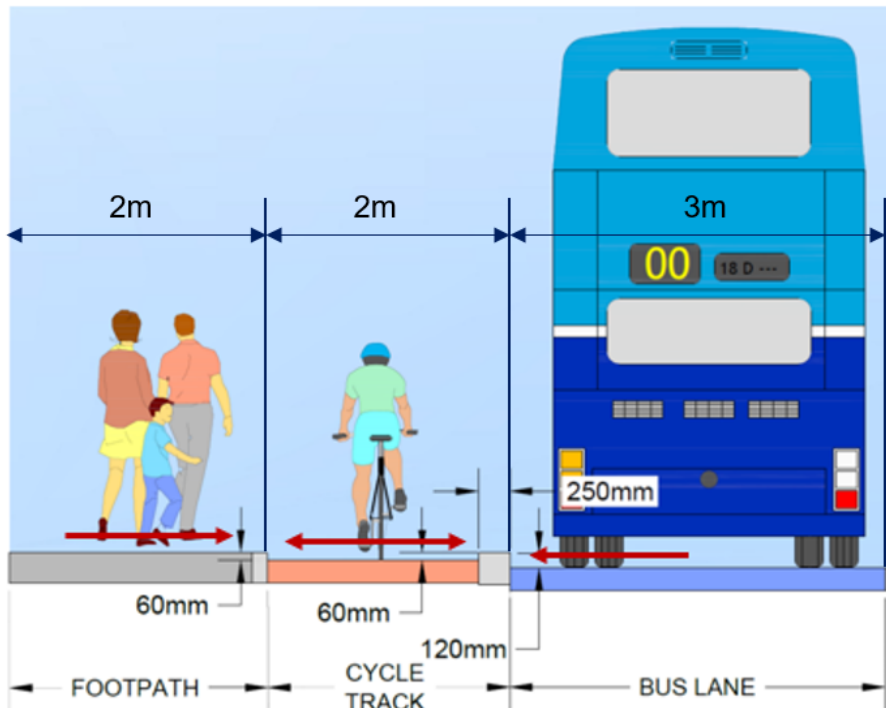

Figure 3: Typical Cross section. Kerb between the Bus lane/carriageway and the cycle track.

1.3 Method of design

The drainage calculation is carried out using MicroDrainage from Innovyze, which is the most widely used drainage design software in the UK and Ireland. The software uses the ‘Modified Rational Method’ to calculate run off from an impermeable area for a storm of a particular return period.

The drainage design for each CBC route shall be developed by using one of the following techniques.

<p>1. Irish Water Model</p>	<p>The Irish Water models can be used to develop the drainage design where it includes comprehensive and known details of the existing surface and combined sewer networks.</p>
<p>2. MicroDrainage (WinDes Model)</p>	<p>A MicroDrainage (WinDes) Model can also be used to develop the design. These models shall be developed, as required, on a catchment-by-catchment basis</p>

3. Hand Calculations	For very small catchments where hydraulic losses and storage within the designed drainage network will be negligible, hand calculations can be used to develop the drainage design.
----------------------	---

As appropriate, each method shall be used to:

- Determine the CBC runoff rates;
- Develop the drainage design including any SuDS to meet the requirements of the Design Basis Document and applicable standards.

As noted elsewhere in this Design Basis Document, a SuDS drainage design shall be developed as a first preference and in accordance with the SuDS hierarchy. Direct discharge to an existing watercourse or drainage network shall only be considered where an appropriate SuDS scheme cannot be developed due to ground conditions or other local constraints, but in such a case online attenuation will be included to control the discharge rate as appropriate. Please refer to Appendix A containing SuDS Eligibility for further information.

2 Proposed drainage strategy

2.1 Relevant Standards and Guidance

It is noted that the purpose of this report is to complement, and not supersede, existing guidance documents relating to the design of drainage in Greater Dublin. A non-exhaustive list of these guidelines is outlined below:

- Greater Dublin Regional Code of Practice (GDRCoP)
- Greater Dublin Strategic Drainage Study (GSDSDS).
- CIRIA The SuDS MANUAL (C753)
- DCC Drainage Planning Section for schemes running completely through greenfield sites.

The following inputs sourced mainly from Met Éireann and GSDSDS Volume 2 are used in the development of the drainage design. Table 1 below shows Rainfall Design Criteria Variables.

Table 1: Rainfall Design Criteria Variables

Variable	Value
Region	Scotland/Ireland
Return Period (GSDSDS Volume 2, Section 6.2 and Drainage Requirements for Planning Applications)	Drainage Network: 1 in 1 no surcharge, Drainage System: 1 in 100 no flooding in greenfield areas only, Drainage System: 1 in 30 years no flooding for extending urban areas
M5-60 (Met Eireann. Return Period Rainfall Depths for sliding Durations. Irish Grid: Easting 315887, Northing: 234669. Values derived from a Depth Duration Frequency Model)	16.3
Ratio R (Met Eireann. Return Period Rainfall Depths for sliding Durations. Irish Grid: Easting 315887, Northing: 234669. Values derived from a Depth Duration Frequency Model)	0.279
Minimum Global Time of Entry (Recommendation for Site Development Works for Housing Areas)	4 minutes
Max. Rainfall (GSDSDS Volume 2 Table 6.4 Surface Water Design Criteria)	50 mm/hr
Max. Time of Concentration (Wallingford Procedure States the Modified Rational Method has only been tested for time of concentration not greater than 30 minutes)	30 minutes
Climate Change	20%

Variable	Value
(Dublin City Council Development Plan 2016-2022 and Drainage Requirements for Planning Applications)	

Table 2 below summarises permeability factors to be used in the design.

Table 2: Runoff permeability factors

Runoff Permeability Factors	
Location	Value
Grassed Areas (Based on Dublin soil type 2)	0.3
Paved	1

Table 3 below summarises soil Standard Percentage Runoff (SPR) values.

Table 3: Soil SPR Values (GSDSDS Volume 2, Table 6.7 SPR Values for Soil)

SOIL	SPR Value
Soil type 1	0.1
Soil type 2	0.3
Soil type 3	0.37
Soil type 4	0.47
Soil type 5	0.53

Surface Water Design Criteria in accordance with GSDSDS is summarized in Table 4 below:

Table 4: Surface Water Design Criteria (GSDSDS Volume 2, Table 6.4 Surface Water Design Criteria)

Parameter	Surface Water Sewers
Minimum depth	1.2m cover under highways 0.9m elsewhere
Maximum depth	Normally 5m
Minimum sewer size	225mm
Runoff factors for pipe sizing	100% paved and roof surfaces 0% off pervious surfaces
Rainfall for initial pipe sizing	50mm/hr rainfall intensity
Minimum velocity (pipe full)	1.0m/s
Flooding	Checks made for adequate protection * No flooding for return period less than 30 years except where explicitly planned Simulation modelling is required for sites greater than 24ha**
Roughness – ks	0.6mm

Table 4 above states minimum pipe sizes, minimum depth of cover, minimum velocity and roughness coefficient.

Minimum slope requirement is set up a good practice as 1 in 500 or steeper. Self-cleansing velocity will take preference.

Table 5 below provides typical values of Q_{BAR} per hectare for the typical SAAR value for Dublin of 750mm for SOIL types 2, 3 and 4.

Table 5: Q_{BAR} values (GSDSDS Volume 2, Table 6.5 Typical Values of Q_{BAR} for Dublin based on 50ha)

	SOIL type 2	SOIL type 3	SOIL type 4
Q_{BAR}/ha (l/s/ha).	2.0	3.1	5.2

2.2 Storm Water Management

It is important to check the effect (pollution, erosion and flooding) of the design on the upstream and downstream infrastructure, especially where the natural run-off is concentrated.

The storm water drainage within the CBC road reserve should thus be designed in such a manner as to ensure that the run-off is conveyed in a controlled manner that will not adversely affect upstream, adjacent or downstream properties.

Where the existing downstream system is clearly inadequate to accommodate the excess storm water run-off from the drainage structures, the following storm water management facilities must be investigated:

- The retarding of the run-off by means of detention facilities. The effect of possible backwater must be checked and investigated (SuDS)

2.3 Sustainable Drainage Systems (SuDS)

Where possible, and in new areas of public realm gained as part of the design, a sustainable drainage system should be considered in the form of rain gardens, bioretention areas, filter drains, swales, tree pits, permeable paving etc. SuDS will also be considered in existing areas where practicable and possible.

The Greater Dublin Strategic Drainage Study introduces SuDS and the available techniques to control the quantity and quality of runoff. It provides guidance on the selection of SuDS for particular sites and discusses issues such as operation and maintenance, cost effectiveness, recreation and amenity, habitat potential and safety.

A SuDS strategy will be extended further in Appendix A.

2.4 Pipe Materials

In accordance with GDRCoP Section 11.3, the following must be used in the construction of main pipelines or connections from gullies or private drains.

The List below applies to all the Local Authorities apart from Dublin City Council who do not approve the use of uPVC pipes in the public area.

- Concrete: Concrete sewer pipes with spigot and socket joints and rubber rings fittings to comply with IS EN 1916 and IS 6 2004 or equivalent standard. Class M or class H. 11.3.2.
- Clayware: Vitrified clay pipes and fittings must comply with the requirements of I.S./EN 295-1/2/3:1992 or equivalent standard. Class 160 or 200. 11.3.3.
- uPVC: Unplasticised P.V.C. pipes must comply with the "Provisional Specification for Soil Pipes, Drains, Sewers and Fittings made of unplasticised P.V.C." issued by the Department of the Environment. B.S. 8005: Part 1 Sewerage or equivalent; B.S. 8010: Part 2 - Pipelines on land or equivalent: design, construction and installation; B.S. 5955: Part 6 Code of Practice for the Installation of unplasticised P.V.C. Pipework for Gravity Drains and Sewers or equivalent EN1401 Unplasticised P.V.C. sewer pipe specification B.S.4514 Unplasticised P.V.C. soil pipe specification Regulations 11.3.4.
- Other: The use of alternative pipe types requires the prior express written approval of the relevant Local Authority.
- Pipe material should not change between manholes.
- The installation of sewers by pipejacking/drilling should have the prior written approval of the relevant Local Authority.
- The Developer must obtain written permission from the relevant Local Authority when pipes are to be laid in landfill, contaminated sites or on poor ground.

2.5 Distance between manholes

In accordance with GDRCoP Section 11.6, the length of pipe-work from manhole to manhole should not exceed 90metres.

2.6 Clash Checks

Existing services & utility drawings/models will be reviewed to support design and proposed location of the various drainage elements within the bus connects corridors. The vertical alignment of existing services and utilities will be considered as far as reasonably practicable (i.e. from site investigations, as-built files etc.). The potential risk from clash of service will be highlighted to the Contractor within the preliminary safety and health plan, and the designer's risk assessment. We are carrying out a utility survey before the planning application that covers clashes with major, critical know utilities only. We are not carrying out an extensive utility survey of all services before planning stage. This will be carried out at a future date after the planning application is complete.

2.7 Bedding Haunching and Surround

In accordance with GDRCoP Section 11.8.1, all main pipelines shall be bedded, haunched and surrounded to the requirements of the Local Sanitary Authority.

In accordance with GDRCoP Section 11.8, the recommended minimum depth of cover over a main pipeline is 1.2m under carriageway and 0.9m elsewhere. If that cannot be achieved, the pipes shall be fully surrounded in 150mm thick concrete with an absolute minimum depth of cover of 750mm, see Figure 4. This applies to both roadways and footpaths. Where concrete bedding is used it must be a minimum of 150mm thick in-situ concrete, class 20N/20mm, and haunched half way up the barrel of the pipe.

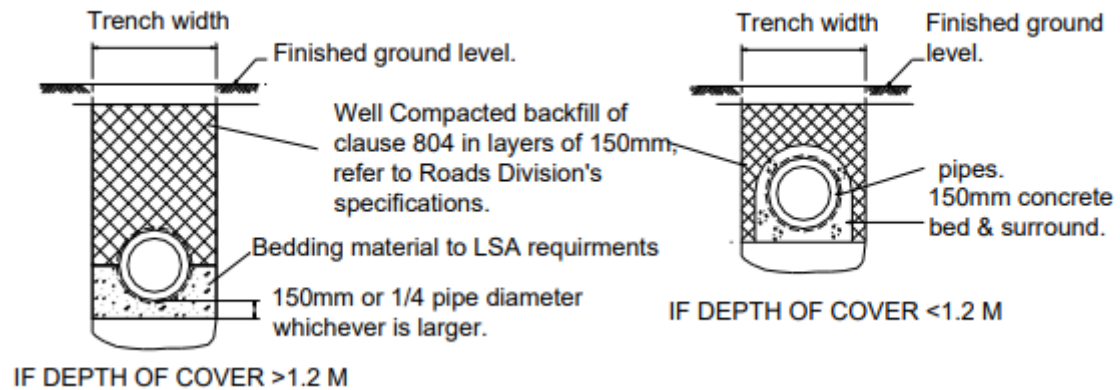

Figure 4: Trench bedding

2.8 CBC design criteria

According to GDSDS Volume 2 Section 6.2, the minimum level of service for the existing network is a 1 in 5-years return period. Given that CBC takes place in a fully urbanised area, it can be assumed that the existing network was designed following these criteria.

The extra impermeable area associated with CBC interventions should be attenuated before discharging to the existing drainage system, ensuring that both the quantity and quality of runoff are appropriate. According to the available data, not all networks can be characterised. Therefore, allowable discharge rates can be assumed as a combination of a flow associated to a 1 in 5-years return period for the existing paved areas plus 2l/s/ha for existing greenfield areas to be paved (additional catchment areas). To achieve this, some SuDS and/or other attenuation facilities such as oversized pipes can be implemented with an outflow control equal to the allowable discharge rate. As a final step to the design process it should be checked that no flooding occurs in the proposed infrastructure for a 1 in 30 year event plus a 20% of climate change allowance. A summary of these design standards is provided in Table 6.

Table 6: Design Standards

Parameter & Feature	Allowable Discharge Rate
<i>Permitted Discharge Rates</i>	
Fully New Paved Catchment Areas	Discharge rates throttled to 2l/s/ha with minimum flow of 2l/s
Combined New/Existing Paved Catchment Areas	Existing runoff rates maintained on the basis of: <ul style="list-style-type: none"> - the existing paved areas to 1 in 5-year flow, or as informed by existing network/model information, plus - 2l/s/ha for the existing grassed areas catchments to be paved (additional catchments).
<i>Attenuation / SuDS Measures</i>	
Combined new/existing paved areas	Attenuation/SuDS measures sized to contain the 1 in 30-year storm with a 20% allowance for future climate change
Fully newly Paved (existing greenfield) Areas	Attenuation/SuDS measures sized to contain the 1 in 100-year storm with a 20% allowance for future climate change
<p>Exceptions:</p> <ul style="list-style-type: none"> • Where attenuation measures are proposed in the floodplain, they shall be sized to contain the 1 in 100-year storm plus climate change • The design of attenuation/SuDS measures shall ensure no new flooding of properties. • Above ground retention of water might be designed to the 1 in 100-year storm plus climate change in situations where the flooding of existing properties might be compromised. 	

The drainage system design must manage on site the quality of runoff to prevent pollution in receiving surface waters and groundwaters. The type of SuDS is chosen to achieve the water quality targets.

In areas where the catchment remains unchanged which implies that no additional impermeable areas are proposed, the design will consist of relocating the gullies to a suitable location. This location will be based on the water pathway that will depend on highway alignment and tie-in requirements. A relevant number of gullies will be located either at the kerb line between the cycle-track and the bus lane, or at the kerb line between the footpath and the cycle track. Further, the spacing of existing gullies will be reviewed to ensure that they are collecting the appropriate run off area.

When schemes run completely through greenfield sites and thus they are not part of an existing network, they will be considered a new development and GDSDS Volume 2 and the Drainage Requirements for Planning Applications will be adhered to.

2.9 Gullies

In accordance with Greater Dublin Regional Code of Practice for Drainage Works Section 14, the following criteria will be adhered to:

- Gullies, gratings and frames shall conform to EN 124, Class D400 or equivalent. Gullies shall be provided for every 200m² of paved area at a minimum, except for low points which may require additional gullies (SuDS design may eliminate the need for gullies in various locations). (GDRCoP Section 14.1)
- Connections from gullies discharging to a combined sewer shall be sealed and from gullies discharging to surface water sewers can be unsealed.
- Interconnection between gullies shall not be permitted. Gully connections shall not exceed 10m in length and shall connect to sewers in the direction of the flow. An additional manhole shall be provided on gullies where the length of the connection pipework is greater than 30m. If gullies are connected to manholes, they shall connect at the benching level or a maximum of 500mm above the invert of the main pipe (GDRCoP Section 14.7)

Appendix A

SuDS Eligibility

Project:	BusConnects	Job No:	
	Technical Paper SuDS Eligibility		For Planning
Subject:	Drainage Design Criteria - SuDS	Date:	23rd Dec 2021
Prepared by:	Elena Calcerrada (GBM-TYPSA), Nick Stokes (JACOBS), Patricia Álvaro (TYPSA)	Version:	Rev B

Drainage Design Criteria – SuDS Eligibility

The aim of this document is to provide a list of Sustainable Drainage Systems (SuDS) options, as designing drainage solutions for the Core Bus Corridors (CBC) project. This document is an appendix of the Drainage Design Criteria. This document has been developed by TYPSA, Green Blue Management (GBM) and JACOBS.



1 LOCAL DRAINAGE GUIDANCE AND REFERENCES

The three main documents of the local drainage guidance are The Greater Dublin Strategic Drainage Study (GDSDS), the Greater Dublin Regional Code of Practice for Drainage Works (v6.0) and the DCC's Drainage Requirements for Planning Applications.

The **Greater Dublin Strategic Drainage Study (GDSDS)** was completed in 2005 and involved the seven Local Authorities of the Greater Dublin Area (GDA), which include Dublin City, Fingal, South Dublin, Dun Laoghaire Rathdown, Meath, Wicklow and Kildare.

While the GDSDS policies remain the over riding documents, the **Greater Dublin Regional Code of Practice for Drainage Works (GDRCoP, v6.0)** sets out the requirements of the Local Authorities in a more concise format for day to day use. In this document, the drainage

requirements are clearly summarised and, particularly, Sustainable Drainage Systems (SuDS) are required in new developments.

Additional references that have been considered are:

- The Dublin City Development Plan 2016-2022. This Plan includes among its objectives the promotion of more natural drainage solutions in line with the SuDS principles.
- Relevant Local Area Plans for all the Dublin Local Authorities
- The “Design Manual for Urban Roads and Streets” (<https://www.dmurs.ie/>).

Finally, it is important to remark that the use of SuDS techniques in urban environments is also one of the key points of the EU policy on Natural Water Retention Measures (NWRM).

2 PRIORITY LEVEL

In addition to local design guidance including the Greater Dublin Strategic Drainage Study and Greater Dublin Regional Code of Practice for Drainage Works, the CIRIA SuDS Manual provides a useful reference for the design of SuDS. The CIRIA SuDS Manual notes that the components of a SuDS scheme should not be thought of in isolation and but as an interconnected system to intercept and manage runoff before it is discharged. The Manual promotes the concept of the SuDS Management Train, as a sequence of components, to collectively manage runoff. A schematic of the SuDS Management Train is provided in Table 1.

Scale		SuDS Management Train
	Source	Rainwater Harvesting – capture and reuse within the local environment
		Pervious Surfacing Systems – structural surfaces that allow water to penetrate into the ground reducing discharge to a drainage system e.g. pervious pavement
	Site	Infiltration Systems – structures which encourage infiltration into the ground e.g. Bioretention Basins
		Conveyance Systems – components that convey and control the discharge of flows to downstream storage components e.g. Swales
Regional	Storage Systems – components that control the flows before discharge e.g. attenuation ponds, tanks or basins	

Table 1 – The SuDS Management Train. Source: produced by Jacobs from CIRIA SuDS Manual 2015

The CIRIA SuDS Manual recommends that when considering SuDS solutions, the preferred approach should be to manage runoff using Source scale solutions where reasonably practicable. Where Source type solutions cannot fully address an increase in runoff from a development, residual flows are discharged to be managed at the Site and then Regional scales.

During Jacobs's recent consultation on the MetroLink drainage design, a key point raised by external Stakeholders was to demonstrate that a SuDS hierarchy had been fully considered in developing the drainage design. This meant that Source and then Site scale solutions had to be fully investigated and shown to be unsuitable before Regional solutions could be considered. Similarly, where a Source or Site scale solution could partially mitigate an increase in runoff this should be progressed to reduce the size of any Regional scale solutions.

Whilst it was recognised that many Source or Site scale solutions might not be suitable to linear infrastructure projects in a constrained urban environment, full documentation of the decision-making process was required to demonstrate compliance with best practice. At a high level, this document is intended to provide a framework for this process, which can be developed for each CBC.

During this process the limitations of the CBC will constrain the final solution for each individual case. Two main constraints have already been identified: available space above and below the ground and low ground infiltration capacity in certain areas. SuDS can not only be effective solving surface runoff but also attenuating surface flows, while at the same time improving water quality and possibly the environment. Throughout the design when selecting the best solution this will be taken into consideration as well as maintenance aspects of each SuDS.

Well-designed SuDS are rarely used for a single function. For that, it is noted that SuDS can be designed with different functions: water conservation and re-use (collection and re-use of surface water), infiltration (encourage stormwater to soak into the ground), detention/attenuation (temporary storage of runoff and slow down flow), retention (permanent storage of runoff), filtration (runoff passes through a filter layer to remove pollutants) and conveyance of runoff.

During the planning stage, ground permeability rate will be assumed to be negligible. Therefore, SuDS will be designed to promote detention rather than infiltration to the ground. This is likely to mean that we 'over-design' our SuDS measures by allowing for additional storage that might actually be required. It is important to remark that some SuDS promote the filtration through porous layers (filter media or permeable pavements) and, for this reason,

water quality can be improved where possible. Refer to the Drainage Design Basis main document for further details.

3 SUDS PROPOSALS

3.1 Introduction

This chapter explains a catalogue of SuDS proposals which fit in our Routes. It is noted that appropriate SuDS techniques must be applied depending on the available space and pollution source. Where reasonably practicable for additional catchment areas, SuDS elements, such as bio-swales or tree-pits will be implemented in order to improve the water quality. By running through porous layers, a level of treatment (and attenuation) will be provided to the flow before discharging into the existing network.

Additionally, physical constraints will be taken into account, such as the ground's low permeability. The following descriptions show a standard solution and, in the next design steps, each intervention should be defined in detail.

3.2 Filter drains

According to GSDSDS (2005) and CIRIA SuDS Manual 2015, filter drains are shallow trenches filled with stone/gravel that create temporary subsurface storage for the attenuation, conveyance and filtration of surface water runoff. A perforated pipe should be provided above the base of the filter drain to collect and convey water to downstream drainage component. Runoff flows slowly through the granular material, trapping sediments and providing attenuation.

An example of a filter drain cross section is given in Figure 1 and examples, in Figure 2.

In Ireland, these features have been already used on the National Road Project serving a dual purpose of groundwater control and runoff drainage.

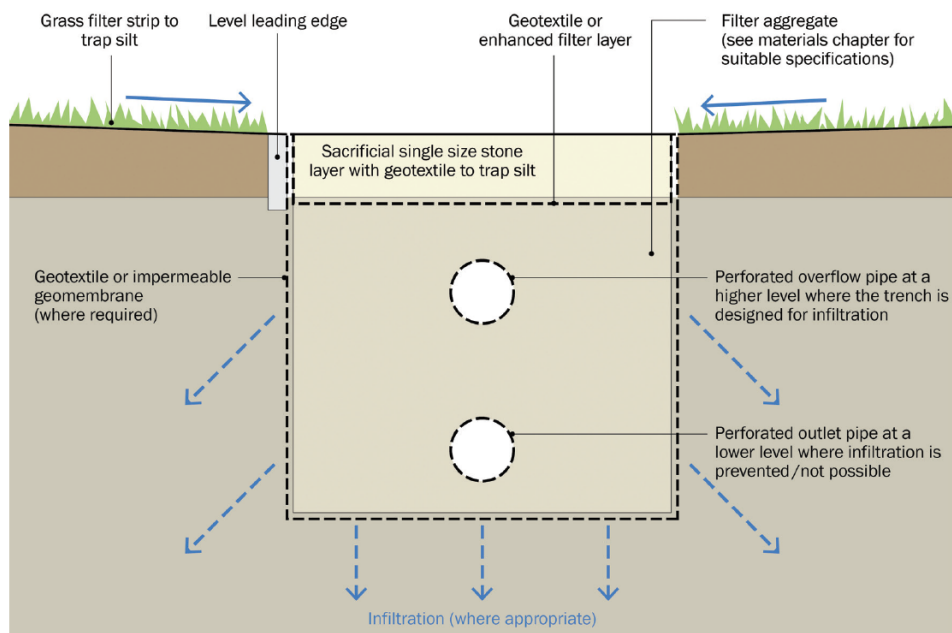

Figure 1. Proposal type 1: Filter drain schematic. Source: CIRIA SuDS Manual 2015 (chapter 16, figure 16.2)



Figure 2. Examples of filter drains. Source: CIRIA SuDS Manual 2015.

3.3 Bioretention systems

According to GSDSDS (2005) and CIRIA SuDS Manual 2015, bioretention systems (including tree pits and rain gardens) are shallow landscaped depressions that can reduce runoff rates and volumes and treat pollution through the use of engineered soils and vegetation. There are many different approaches to the design of bioretention systems and rain gardens; however, the main components that are usually provided in a bioretention systems are shown in Figure .

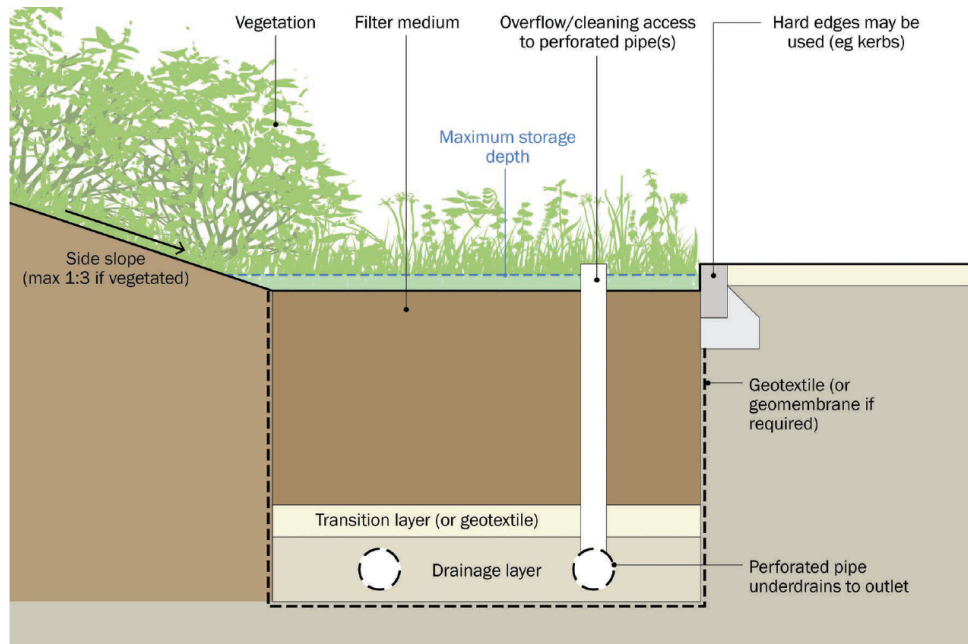

Figure 3. Type 2: Bioretention system. Source: CIRIA SuDS Manual 2015 (chapter 18, figure 18.1)



Figure 4 Example of previously proposed public realm designs for Dublin using SuDS. Source: DCC



Figure 5 Example of previously proposed public realm designs for Dublin using SuDS. Source: DCC

3.4 Permeable pavements

According to GSDS (2005) and CIRIA SuDS Manual 2015, permeable pavements are designed to reduce imperviousness, minimizing surface runoff. There is a wide range of types from porous asphalt and concrete to modular paving (large gaps between impervious areas allows infiltration). Permeable pavements might be used in parking bays with a parallel drainage system in place (and providing DCC - Road Maintenance approval) in order to allow rainwater to infiltrate through the surface and into the underlying structural layer. The water is temporarily stored beneath the overlying surface before use, infiltration to the ground, or controlled discharged (Figure 6).

Pervious surfaces, together with their associated substructures, are an efficient mean of managing surface water runoff close to its source – intercepting runoff, reducing the volume and frequency of runoff, and providing a treatment medium.

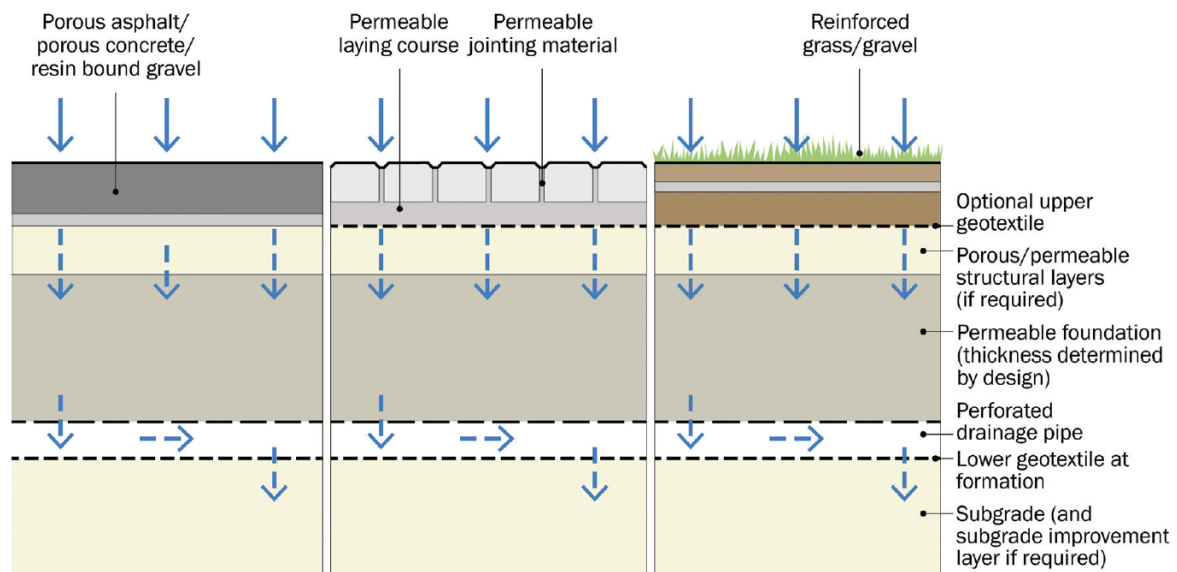

Figure 6. Type 3: Permeable pavement systems types (partial infiltration). Source: CIRIA SuDS Manual 2015 (chapter 20, figure 20.13)

3.5 Opportunity spaces

Opportunity spaces are open spaces clear from utilities and valuable trees. These spaces can be used as green infrastructure areas and might be located:

- Along the route of the project where the existing catchment remains unchanged.
- In the vicinity of the route and outside the project boundary.

For lengths of the scheme where additional impermeable areas are included but there is no space available for SuDS and/or attenuation, opportunity spaces upstream of the said areas might be used to offset the additional flows.

4 BUSCONNECTS SuDS SELECTION

4.1 SuDS Selection Hierarchy

We have applied a hierarchical approach to select SuDS drainage solutions for each of the BusConnects routes. This drew upon the management train approach in the CIRIA SuDS Manual Hierarchy (see Section 2) and “Guidance on SuDS Requirements in Fingal County Council - DS 17-12-19” document.

Our approach to select appropriate SuDS drainage solutions on the BusConnects project recognises wider scheme constraints, principally land availability, to ensure proposed measures are proportionate and will not unduly impact on sensitive private lands. We have followed a 5-stepped approach with Step 1 being the most preferable option and Step 5 being the least and option of last resort.

The SuDS measures are selected to ensure no net increase in runoff and to maximise the potential for runoff quality improvements. On this basis, ‘Source’ type measures (see Section 2) are preferred as they provide early interception and the greatest potential to slow runoff flows, removing sediments and other pollutants. Oversized pipes or attenuation tanks are used only as the option of last resort where all other measures have been found to be impractical. Where oversized pipes or attenuation tanks are required they should, where practicable, be implemented in combination with either Source or Site type attenuation measures.

Our site selection process is shown in Table 2 below.

Step	Question	Action
1	Can a Raingarden, Filter Drain, Swale/Bioretention area, Tree Pit or other Source Control type SuDS solution be implemented within the redline boundary?	Yes – stop, preferred approach No – move to Step 2
2	Can the redline boundary be extended into low impact lands e.g. public green space to accommodate a Raingarden, Filter Drain, Swale/Bioretention area, Tree Pit or other Source Control type SuDS solution?	Yes – stop, preferred approach, use in combination with Step 1 if appropriate No – move to Step 3
3	Can a Site Control measure (e.g. Dry Detention Basin) be implemented in addition to Source Control within the redline boundary?	Yes – stop, preferred approach, seek to maximise source control measures and minimise size of Site Control Measures No - move to step 4
4	Can the redline boundary be extended into low impact lands e.g. public green space to accommodate a Site Control measure (e.g. Dry Detention Basin) supplemented, where possible by a Raingarden, Filter Drain, Swale/Bioretention area, Tree Pit or other Source Control type SuDS solution?	Yes – stop, preferred approach, seek to maximise source control measures and minimise size of Site Control Measures No - move to step 5

Step	Question	Action
5	Can oversized pipes and/or an attenuation tank be used to ensure no increase in runoff?	Yes – note option of last resort and source/site measures should be used in addition where possible. Any extension of the redline boundary is to be into low impact lands only

Table 2 – SuDS Selection Hierarchy

4.2 Vegetation species selection

In 2011, Forest Research provided a simple rating of the soil salt tolerance of common species in the UK. This list is non-exhaustive, and complementary advice should be sought from a tree specialist as well as the supplying tree nursery.



Appendix: Tolerance to soil salt of common tree species

Tolerance	Species
Tolerant	<i>Alnus glutinosa</i>
Tolerant	<i>Elaeagnus angustifolia</i>
Tolerant	<i>Gleditsia triacanthos</i>
Tolerant	<i>Pinus nigra</i> (all varieties/subspecies)
Tolerant	<i>Picea pungens</i>
Tolerant	<i>Quercus robur</i>
Tolerant	<i>Robinia pseudoacacia</i>
Tolerant	<i>Salix alba</i>
Tolerant	<i>Ulmus glabra</i>
Intermediate	<i>Acer campestre</i>
Intermediate	<i>Alnus incana</i>
Intermediate	<i>Crataegus monogyna</i>
Intermediate	<i>Carpinus betulus</i>
Intermediate	<i>Fagus sylvatica</i>
Intermediate	<i>Fraxinus excelsior</i>
Intermediate	<i>Picea abies</i>
Intermediate	<i>Pinus contorta</i>
Intermediate	<i>Pseudotsuga menziesii</i>
Intermediate	<i>Sorbus aucuparia</i>
Intermediate	<i>Thuja occidentalis</i>
Sensitive	<i>Acer pseudoplatanus</i>
Sensitive	<i>Aesculus</i> species
Sensitive	<i>Betula pubescens</i>
Sensitive	<i>Cornus</i> species
Sensitive	<i>Corylus</i> species
Sensitive	<i>Larix decidua</i>
Sensitive	<i>Platanus x hispanica</i>
Sensitive	<i>Prunus avium</i>
Sensitive	<i>Tilia cordata</i>
Sensitive	<i>Tilia platyphyllos</i>

Figure 7. Tolerance to soil salt of common tree species. Source: Forest Research (2011).

4.3 Examples of application

The proposed SuDS technique must be chosen to achieve both the water quantity and quality targets. According to "SuDS for Roads" (2009): *"Within new developments it is generally accepted that two levels of SUDS treatment are required for surface water runoff from roads, although a single level of treatment may be acceptable for smaller residential developments. Some individual components provide two levels, such as permeable pavements and dry swales. Where consideration of alternative SUDS is being given, two or more components linked in series may be required, depending on the type of development on the site."*

The design criteria to allow runoff from the road into the SuDS is preferred to maximize both quality and space requirements, being also a more cost-effective approach. This criterion implies that salty water will be collected by the SuDS and; for this reason, the selection of vegetation species shall be done attending to the salt tolerance.

Therefore, the following SuDS techniques can be applied:

- **Bioretention areas** located along the routes, updating the existing green stripes. If runoff of the road is collected, the filter medium must satisfy the conditions below:
 1. The permeability should be between 100 and 300 mm/h.
 2. 1.00 m depth is compulsory.

It is noted that bioretention areas will contain **ground cover plants**; and **trees are not required in terms of quality requirements**. Trees will be considered only due to landscape purposes and avoiding in this case collecting runoff from the road.
- **Permeable pavements** in car parks.

Regarding the location of the SuDS element, some key aspects shall be also taken into account:

1. Existing trees and streetlights shall be retained. For this reason, spaces clear from utilities and veteran trees inside the existing green stripes are preferable.
2. If there is not enough available space there where additional impermeable areas are located, the existing green stripes upstream of the location where additional runoff is generated shall be used. Thus, it can be guaranteed that the drainage system will have capacity to convey the resultant flow.
3. In order to optimize the construction, those green stripes which require some updating (because of implementing the Bus Connects Corridors) shall be prioritized.

Some examples of application are shown in the figures below:

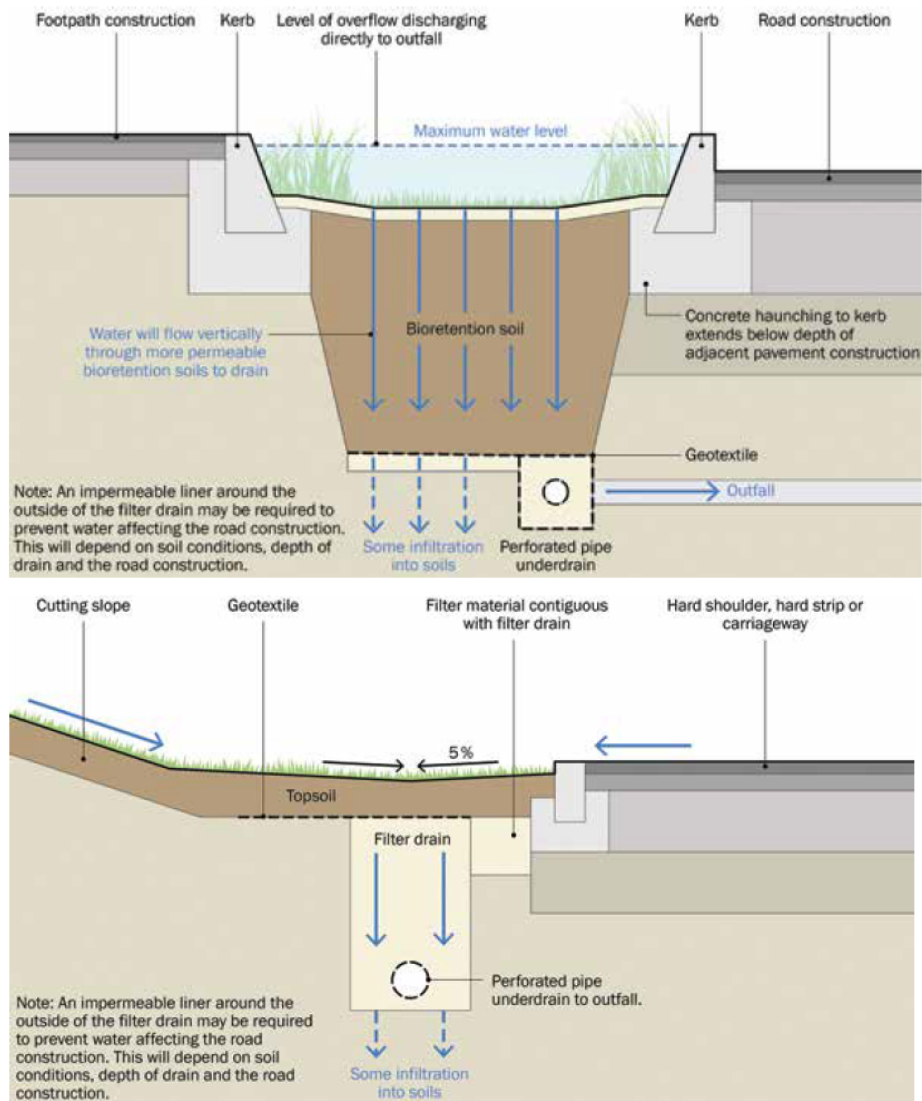

Figure 8. Example of implementation of SuDS elements at the side of roads. Source: CIRIA SuDS Manual 2015 (chapter 9, figures 9.12 and 9.14).

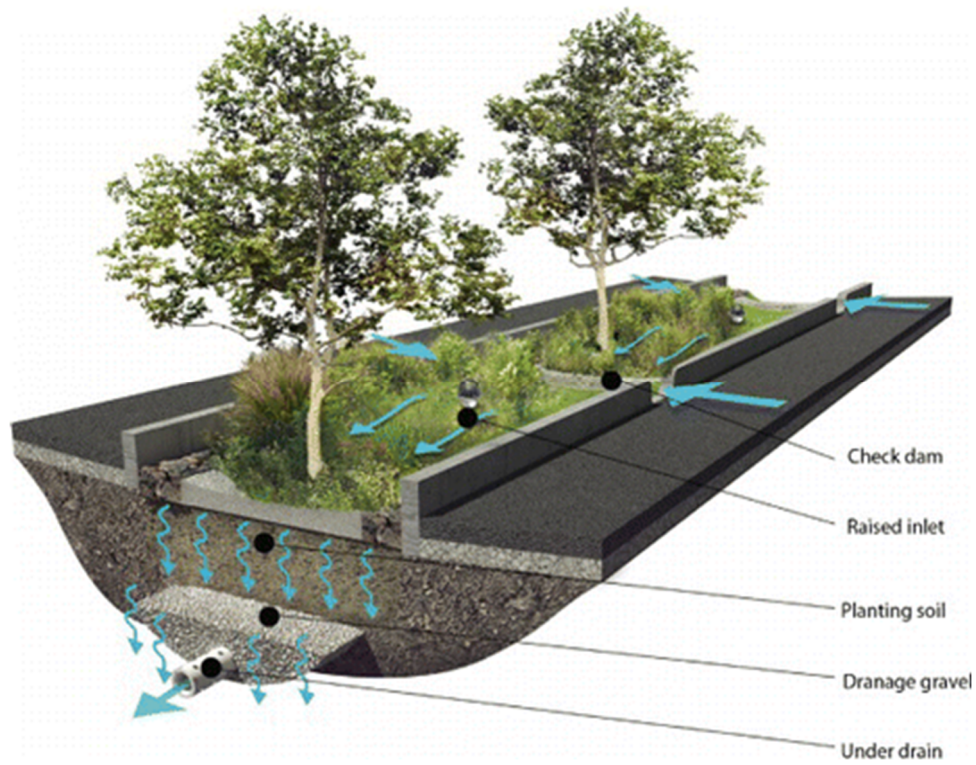

Figure 9. Example of bioretention area collecting road runoff. Source: Artful Rainwater Design: Creative Ways to Manage Stormwater (2015).

Appendix B

Bus Connects – Road run-off
collection gullies

Subject BusConnects - Road run-off collection gullies

To National Transport Authority

From Mott MacDonald/AECOM

Our reference BCIDA-ACM-DNG_RD-0001-XX_00_M-CD-001_REV C

Date December 2021

1 Overview

This technical note reviews the feasibility and efficiency of using other types of gully gratings/inlets to accommodate surface water run-off along the new BusConnects Core Bus Corridors, while re-using the existing drainage infrastructure.

Gullies are the primary collection system where kerbs are present to drain the carriageway and hard surfaces around the city. A use of existing gully grating pots is being reviewed to increase safety on cycleways and increase the ride quality along bus lanes.

1.1 General

Most routes along the Dublin BusConnects Core Bus Corridors are along National Roads. Therefore, this document has been prepared with reference to the following NRA Documents and requirements:

- Volume 4 Section 2 Part 3 NRA HD 33/15 Drainage Systems for National Roads
- Volume 4 Section 2 Part 3 NRA HD 102/15 Spacing of Road Gullies

The design procedure used for the determination of the allowable spacing for the road gullies/ kerb inlets is that as describe in Volume 4 Section 2 Part 3 NRA HD 102/15 Spacing of Road Gullies (referred herein as the Standard). Four different stormwater collection systems are considered for comparison within this document:

1. Gully Collection System #1: Typical Gully (See Figure 1)

This option considers the use of a standard gully grating and in situ block work gully pot, laid adjacent to the carriageway kerb, allowing for a total carriageway surcharge flow width of 0.5m from the kerb.

2. Gully Collection System #2: 0.5m Wide Kerb Inlet Gully (See Figure 2)

This option considers the use of a 0.5m wide kerb inlet gully, allowing for a total carriageway surcharge flow width of 0.5m from the kerb. Depending on site specific conditions (kerb profile), the use of a standard or non-standard unit will be required.

3. Gully Collection System #3: Proprietary Split Grating and Kerb Gully Unit (See Figure 3)

This option considers the use of a standard split grating and kerb gully unit which would fit the finished kerb cross section. This option allows for a total carriageway surcharge flow width of 0.5m from the kerb.

4. Gully Collection System #4: Narrow Profile Gully (See Figure 4)

This option considers the use of a narrow profile gully, with standard DCC or TII gully pots and an allowable surcharge flow width of 0.5m from the kerb.

1.1.1 Gully Collection System #1

Figure 1 shows the TII Standard Construction Detail for in-situ concrete and blockwork gullies from the Greater Dublin Regional Code of Practice for Drainage Works.

Figure 1: Gully Collection System #1: Typical In-Situ and Blockwork Gullies

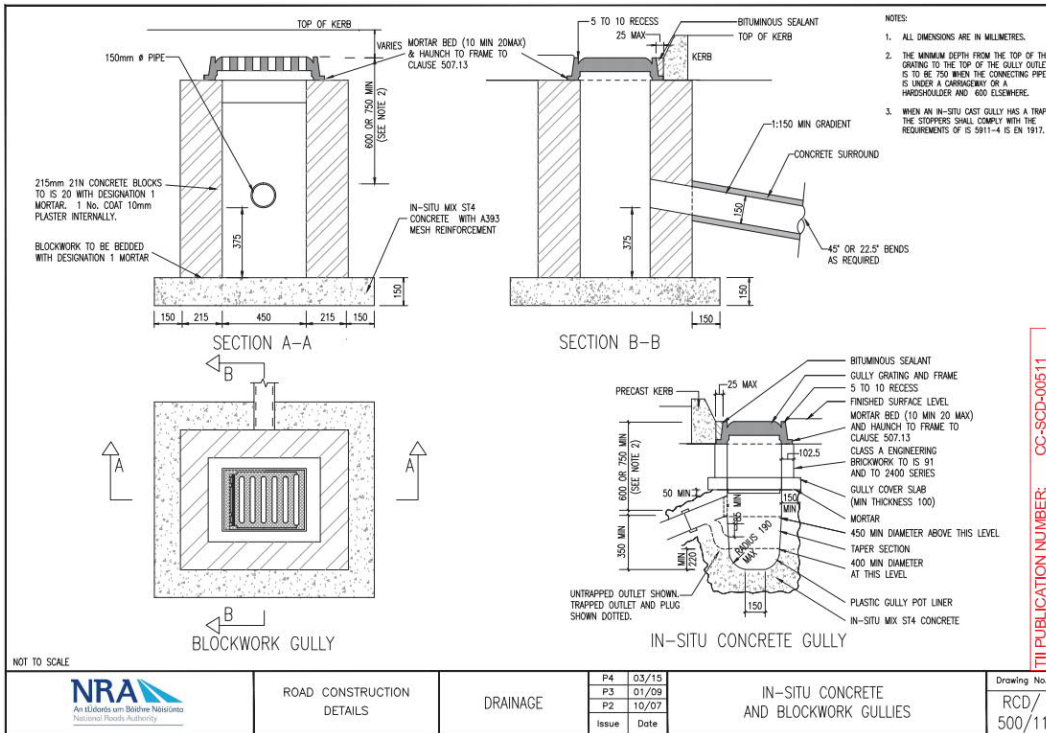
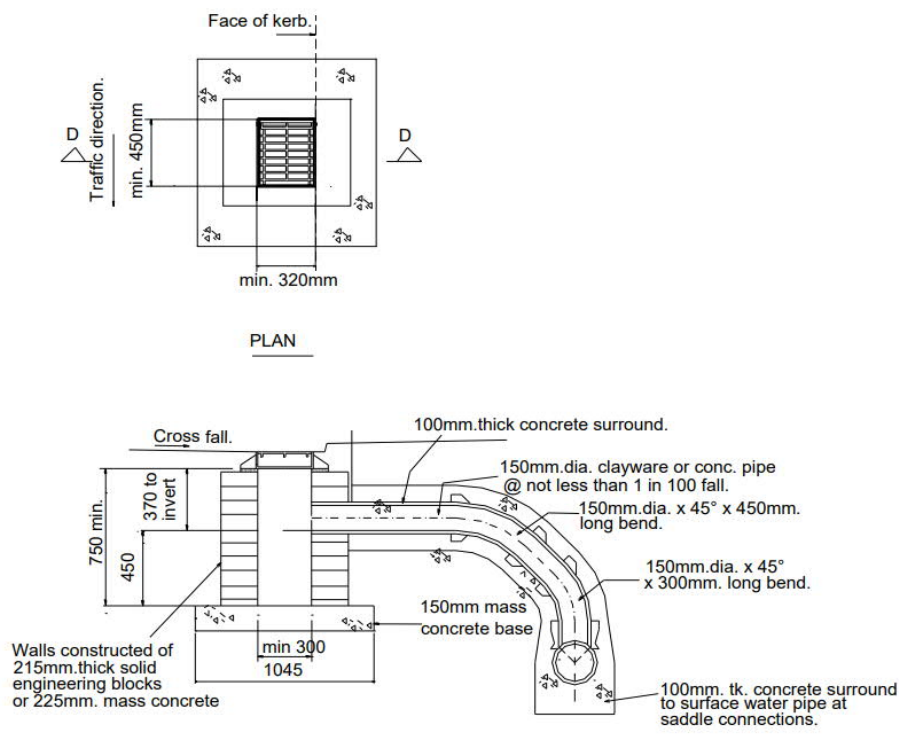

Figure 2: Typical Blockwork Gullies



1.1.2 Gully Collection System #2

Depending on site specific conditions (kerb profile), a standard or non-standard kerb inlet unit would be appropriate for the collection system. Figure 3 illustrates the location where a standard kerb inlet unit would be suitable, due to the depth of the kerb between the cycleway and bus lane.

Figure 4 shows a typical section, and plan, of the gully pot and a non-standard kerb gully unit. The non-standard unit would be required for this system as the proposed geometry of the kerb line between the bus lane and the cycleway such that a side inlet gully would not fit into the proposed profile.

Figure 3: Site condition allowing for use of standard kerb inlet gully unit

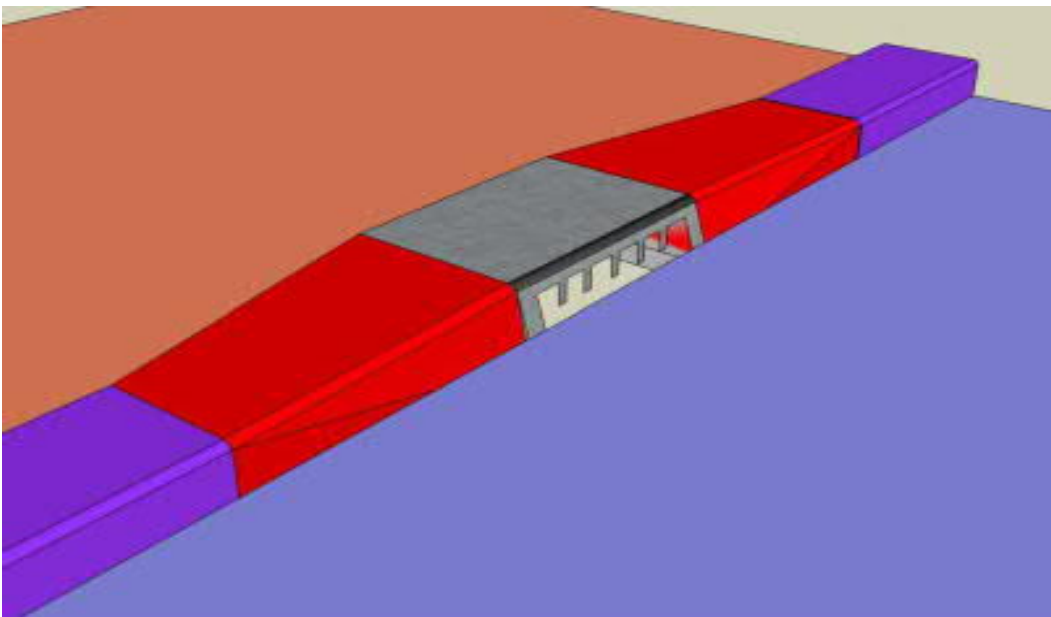
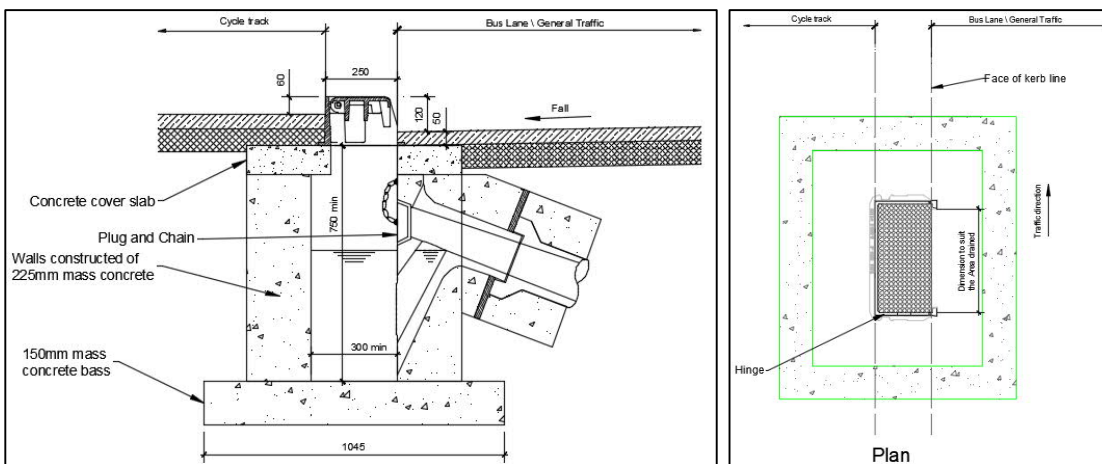

Figure 4: Gully Collection System #2: Non-standard 0.5m Wide Kerb Inlet



1.1.3 Gully Collection System #3

The proposed Proprietary grating and kerb gully unit is as shown in Figure 5.

Figure 6 and Figure 7 provide a street view of the typically installation, and the hinged opening respectively, of this type of unit.

Figure 5: Gully Collection System #3: Proprietary Split Grating and Kerb Gully Unit

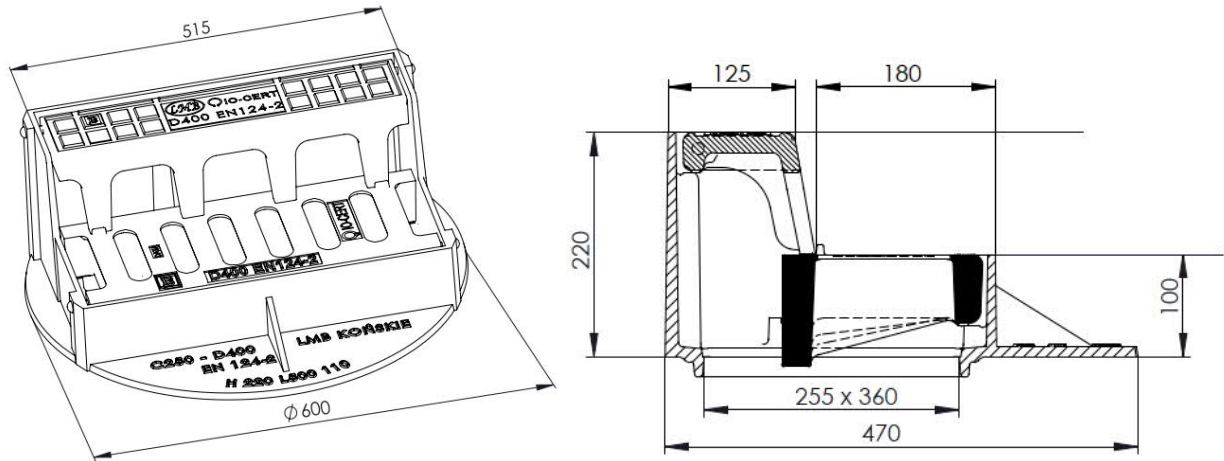

The total collection area (grating and side inlet) of this unit is 650cm².

The maximum spacing of this split grating and kerb collection system was determined from first principles using the formulas within Sections 5.12, 5.13, 5.14, 5.15, and 5.17 of the Design Standard.

The maximum spacing has been determined by calculating the specific G Value for the combined unit based on assumptions of the Ag and P values (it should be noted that relatively large variations in these values has minimal impact on the overall maximum spacing). The collection efficiency of the side inlet and the gully grating were calculated independently, and the value of the more efficient component was used as the design efficiency to determine the maximum spacing

Figure 6: Typical Installation of Split Grating and Kerb Gully Unit



Figure 7: Typical Hinged Opening of Split Grating and Kerb Gully Unit

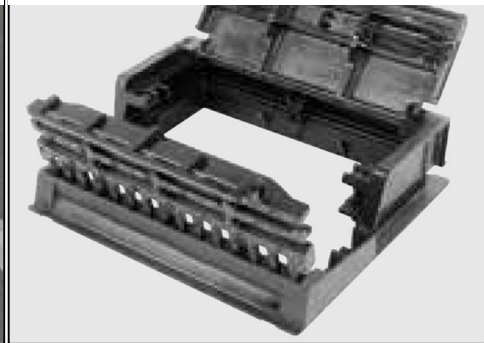

1.1.4 Gully Collection System #4

Narrow Profile Hinged Gully Grating similar to proprietary shown in Figure 8 and Figure 9 was reviewed. This innovative product avoids excessive clipping by traffic and removes gully units within the wheel track and offers better ride quality. With a grating is rated D400 and is less than 300 mm wide, the grating profile is safer for cyclists who are sometimes needs to swerve to avoid ironwork in the road and is outside the wheel track.

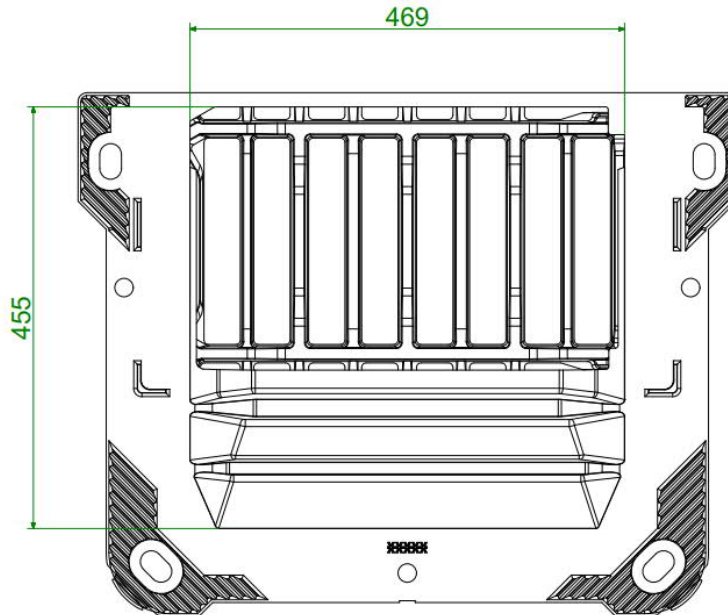

Figure 8: Typical Narrow Profile Gully Unit



Figure 9: Typical Narrow Profile Gully Unit

1.2 Rainfall & Maintenance Factor

The design rainfall intensity was calculated using Equation (1) of the Standard using the following criteria:

Criteria	Value	Justification
Design Storm Return Period	1 Years	In accordance with Section 6 of HD 33/15
Critical Storm Duration	5 Minutes	In accordance with Section 5 of HD 102/15
2minM5 (<i>rainfall depth occurring in 2 minutes with a return period of 5 years</i>)	3.14 mm	Derived from Flood Studies Report maps
Climate Change Allowance	20%	In accordance with Dublin City Council Development Plan 2016 - 2022

Based on these criteria, the design rainfall is 52.08mm/hr.

The maintenance factor applied for the various options in considered to be 1.0 (well-maintained urban roads).

1.3 Design Methodology

The design tables within Appendix C of the HD 102/15 were used in combination with Equation (2) to determine the maximum drainage unit spacings. The calculation assumes that the footpath and cycleway would drain towards the bus lane, with the collection units located along the kerb between the bus lane and the cycle lane.

The design catchment width will ultimately be determined by the collective drainage design for the footpath, cycleway, and carriageway. Depending on site specific conditions along the various corridors (e.g. longitudinal gradient, crossfall etc.) it may be necessary to utilise a dual collection unit with one unit to collecting drainage from the cycleway/footpath and one unit collecting the carriageway drainage.

Therefore, the design catchment width may vary to include the footpath, cycleway, and carriageway in some areas, and the carriageway only in other areas. As a result, this document considers the required spacing of the drainage units, for the above-mentioned options, for a catchment width of 10.5m (footpath, cycleway & carriageway) and 6.5m (carriageway only).

Gully tops shall meet the requirements of EN124 load classifications the appropriate class of a manhole top or a gully top to be used depends upon the place of installation. The minimum class recommended for use in each group is shown in brackets. Areas which can only be used by pedestrians and pedal cyclists.

— Group 3 (at least class C 250): Pedestrian areas and comparable areas, car parks or car parking decks. For gully tops, installed in the area of kerbside channels of roads (Figure 7) which, when measured from the kerb edge, extends a maximum of 0,5 m into the carriageway and a maximum of 0,2 m into the pedestrian area.

— Group 4 (at least class D 400): Carriageways of roads (including pedestrian streets), hard shoulders (Figure 10) and parking areas, for all types of road vehicles

Figure 10: Typical highway cross- section showing the location of the groups

For concave gratings the places of installation shall be limited to the following places of intended uses:

- Groups 1, 2 and 3;
- Group 4, for parking areas only.

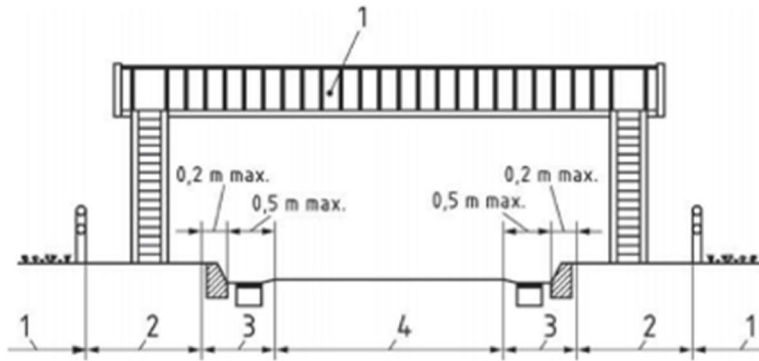

Key

- 1 Group 1
- 2 Group 2
- 3 Group 3
- 4 Group 4

Figure 8: Typical detail of a hard shoulder showing the location of the groups

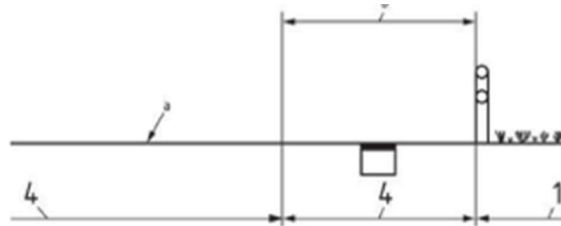

Key

- 1 Group 1
- 4 Group 4
- a carriage way
- b hard shoulder

2 Comparison of Options

The maximum spacing of gullies, non-standard kerb inlets, & split grating and kerb units for the various road gradients and crossfalls is shown in Table 1. A comparison of the spacings for the carriageway, footpath and cycleway catchment and the carriageway catchment only, is also shown.

Table 1: Comparison of various collection systems:

Drainage of Footpath, Cycleway & Carriageway 10.5m Catchment					
Crossfall (Sc)	Gradient (Sl)	System #1: Typical Gully Max Spacing (m)	System #2: Non-standard Kerb Inlet Max Spacing (m)	System #3: Split Grating and Kerb Gully Unit Max Spacing (m)	System #4: Narrow Gully Max Spacing (m)
1/60	1/300	1.19	1.01	1.16	1.19
	1/150	1.65	1.28	1.63	1.65
	1/100	2.01	1.46	1.97	2.01
	1/80	2.19	1.55	2.20	2.29
	1/60	2.56	1.65	2.51	2.56
	1/50	2.74	1.65	2.74	2.83
	1/40	3.02	1.74	3.04	3.11
	1/30	3.47	Not Efficient	3.47	3.66
	1/20	4.21	Not Efficient	4.16	4.39
	1/15	4.75	Not Efficient	4.72	5.03
1/50	1/300	1.55	1.37	1.56	1.55
	1/150	2.19	1.74	2.17	2.19
	1/100	2.65	1.92	2.63	2.74
	1/80	2.93	2.01	2.91	3.02
	1/60	3.38	2.19	3.33	3.47
	1/50	3.66	2.19	3.62	3.84
	1/40	4.11	2.29	4.00	4.21
	1/30	4.66	Not Efficient	4.54	4.85
	1/20	5.58	Not Efficient	5.41	5.85
	1/15	6.31	Not Efficient	6.10	6.77
1/40	1/300	2.29	1.92	2.21	2.29
	1/150	3.11	2.47	3.06	3.20
	1/100	3.84	2.74	3.69	3.93
	1/80	4.21	2.93	4.08	4.39
	1/60	4.85	3.11	4.63	5.03
	1/50	5.30	3.11	5.01	5.49
	1/40	5.85	3.20	5.51	6.13
	1/30	6.67	Not Efficient	6.21	6.95
	1/20	7.95	Not Efficient	7.28	8.41
	1/15	8.96	Not Efficient	8.09	9.60
1/30	1/300	3.57	3.02	3.44	3.66
	1/150	5.03	3.84	4.69	5.12
	1/100	6.03	4.30	5.58	6.22

Drainage of Footpath, Cycleway & Carriageway 10.5m Catchment

Crossfall (Sc)	Gradient (SL)	System #1: Typical Gully Max Spacing (m)	System #2: Non-standard Kerb Inlet Max Spacing (m)	System #3: Split Grating and Kerb Gully Unit Max Spacing (m)	System #4: Narrow Gully Max Spacing (m)
	1/80	6.77	4.57	6.12	6.95
	1/60	7.68	4.75	6.87	7.95
	1/50	8.32	4.94	7.37	8.69
	1/40	9.23	Not Efficient	8.00	9.69
	1/30	10.42	Not Efficient	8.83	11.06
	1/20	12.43	Not Efficient	9.99	13.35
	1/15	13.90	Not Efficient	10.73	15.18
1/25	1/300	4.85	4.02	4.50	4.94
	1/150	6.67	5.12	6.05	6.95
	1/100	8.14	5.76	7.11	8.41
	1/80	8.96	6.03	7.73	9.33
	1/60	10.24	6.31	8.56	10.70
	1/50	11.06	6.40	9.09	11.70
	1/40	12.25	Not Efficient	9.73	12.98
	1/30	13.81	Not Efficient	10.50	14.81
	1/20	16.37	Not Efficient	Not Efficient	17.83
	1/15	18.29	Not Efficient	Not Efficient	20.30
1/20	1/300	6.95	5.85	6.14	7.13
	1/150	9.60	7.31	8.02	9.87
	1/100	11.52	8.23	9.20	12.07
	1/80	12.80	8.59	9.83	13.35
	1/60	14.54	8.96	10.59	15.27
	1/50	15.73	8.96	11.01	16.64
	1/40	17.28	Not Efficient	Not Efficient	18.47
	1/30	19.48	Not Efficient	Not Efficient	21.12
	1/20	22.86	Not Efficient	Not Efficient	25.33
	1/15	25.51	Not Efficient	Not Efficient	28.71
1/15	1/300	10.97	9.14	8.73	11.25
	1/150	15.09	11.52	10.64	15.73
	1/100	18.10	12.80	Not Efficient	19.02
	1/80	19.93	13.35	Not Efficient	21.12
	1/60	22.58	13.81	Not Efficient	24.14
	1/50	24.41	Not Efficient	Not Efficient	26.24
	1/40	26.79	Not Efficient	Not Efficient	29.08
	1/30	29.99	Not Efficient	Not Efficient	33.10
	1/20	34.84	Not Efficient	Not Efficient	39.50
	1/15	38.40	Not Efficient	Not Efficient	44.62

Drainage of Carriageway 6.5m Catchment Only

Crossfall (Sc)	Gradient (Sl)	System #1: Typical Gully Max Spacing (m)	System #2: Non-standard Kerb Inlet Max Spacing (m)	System #3: Split Grating and Kerb Gully Unit Max Spacing (m)	System #4: Narrow Profile Gully Max Spacing (m)
1/60	1/300	1.92	1.62	1.88	1.92
	1/150	2.66	2.07	2.63	2.66
	1/100	3.25	2.36	3.19	3.25
	1/80	3.54	2.51	3.55	3.69
	1/60	4.14	2.66	4.06	4.14
	1/50	4.43	2.66	4.42	4.58
	1/40	4.87	2.81	4.91	5.02
	1/30	5.61	Not Efficient	5.60	5.91
	1/20	6.79	Not Efficient	6.72	7.09
	1/15	7.68	Not Efficient	7.63	8.12
1/50	1/300	2.51	2.22	2.52	2.51
	1/150	3.54	2.81	3.50	3.54
	1/100	4.28	3.10	4.24	4.43
	1/80	4.73	3.25	4.71	4.87
	1/60	5.46	3.54	5.37	5.61
	1/50	5.91	3.54	5.84	6.20
	1/40	6.65	3.69	6.46	6.79
	1/30	7.53	Not Efficient	7.34	7.83
	1/20	9.01	Not Efficient	8.74	9.45
	1/15	10.19	Not Efficient	9.85	10.93
1/40	1/300	3.69	3.10	3.58	3.69
	1/150	5.02	3.99	4.95	5.17
	1/100	6.20	4.43	5.96	6.35
	1/80	6.79	4.73	6.59	7.09
	1/60	7.83	5.02	7.48	8.12
	1/50	8.57	5.02	8.09	8.86
	1/40	9.45	5.17	8.90	9.90
	1/30	10.78	Not Efficient	10.03	11.23
	1/20	12.85	Not Efficient	11.76	13.59
	1/15	14.47	Not Efficient	13.07	15.51
1/30	1/300	5.76	4.87	5.56	5.91
	1/150	8.12	6.20	7.58	8.27
	1/100	9.75	6.94	9.02	10.04
	1/80	10.93	7.39	9.89	11.23
	1/60	12.41	7.68	11.10	12.85
	1/50	13.44	7.98	11.90	14.03

Drainage of Carriageway 6.5m Catchment Only

Crossfall (Sc)	Gradient (Sl)	System #1: Typical Gully Max Spacing (m)	System #2: Non-standard Kerb Inlet Max Spacing (m)	System #3: Split Grating and Kerb Gully Unit Max Spacing (m)	System #4: Narrow Profile Gully Max Spacing (m)
	1/40	14.92	Not Efficient	12.92	15.66
	1/30	16.84	Not Efficient	14.27	17.87
	1/20	20.09	Not Efficient	16.14	21.56
	1/15	22.45	Not Efficient	17.33	24.52
1/25	1/300	7.83	6.50	7.28	7.98
	1/150	10.78	8.27	9.77	11.23
	1/100	13.15	9.31	11.48	13.59
	1/80	14.47	9.75	12.49	15.07
	1/60	16.54	10.19	13.83	17.28
	1/50	17.87	10.34	14.68	18.91
	1/40	19.79	Not Efficient	15.72	20.97
	1/30	22.30	Not Efficient	16.96	23.93
	1/20	26.44	Not Efficient	Not Efficient	28.80
	1/15	29.54	Not Efficient	Not Efficient	32.79
1/20	1/300	11.23	9.45	9.92	11.52
	1/150	15.51	11.82	12.96	15.95
	1/100	18.61	13.29	14.86	19.50
	1/80	20.68	13.88	15.88	21.56
	1/60	23.48	14.47	17.11	24.67
	1/50	25.40	14.47	17.78	26.88
	1/40	27.92	Not Efficient	Not Efficient	29.84
	1/30	31.46	Not Efficient	Not Efficient	34.12
	1/20	36.93	Not Efficient	Not Efficient	40.91
	1/15	41.21	Not Efficient	Not Efficient	46.38
1/15	1/300	17.72	14.77	14.10	18.17
	1/150	24.37	18.61	17.19	25.40
	1/100	29.24	20.68	Not Efficient	30.72
	1/80	32.20	21.56	Not Efficient	34.12
	1/60	36.48	22.30	Not Efficient	38.99
	1/50	39.44	Not Efficient	Not Efficient	42.39
	1/40	43.28	Not Efficient	Not Efficient	46.97
	1/30	48.45	Not Efficient	Not Efficient	53.47
	1/20	56.27	Not Efficient	Not Efficient	63.81
	1/15	62.03	Not Efficient	Not Efficient	72.08

For a typical road crossfall of 2.5% the efficiency of a narrow gully appears to be similar to a typical gully.

3 Conclusion & Recommendations

A review of the allowable spacing of the various gully collection systems shows that in an urban situation a side inlet kerb is the least efficient. If this option (side inlet kerb) was utilised, the number of gullies required would increase by a factor of approx. 75%, when compared with the proposed options. This can be seen in Table 1 which outlines the maximum gully/ kerb inlet spacing for the corresponding road gradients and crossfalls.

Typical gully unit, the split grating and kerb unit and narrow profile gullies have similar discharge capacities across the various gradients and crossfalls, with the narrow profile gullies slightly more effective.

Split grating and kerb unit does not meet Dublin City Council drainage maintenance requirements and therefore not recommended.

The narrow profile gullies reduce risks associated with gully gratings being laid within the carriageway outside the wheel running track of buses and will improve ride quality.

Proper construction of the gully pot blockwork and foundation should mitigate against this risk of any settlement of gully pots.

Based on review of existing drainage system, discussion with local authorities the following surface water collection strategy is being proposed to complement the narrow profile gully.

- In the interest of Water Quality all proposed gullies shall contain a sump that will trap debris & prevent siltation, to enter the drainage networks.
- Where existing gullies are present a narrow profile gully as shown in Appendix A should be retrofitted wherever practicable.
- Where existing combined gully are in the carriageway single units shall be connected using separation chambers and rodding facility as detailed in Appendix B.

Refer to Table 2 for pros and cons of the use of a typical gully, kerb inlet gully, split grating and kerb gully and narrow profile gullies.

Table 2: Pros and Cons of Various Gully Units

Typical Gully Unit		Kerb Inlet Gully Unit		Split Grating and Kerb Gully Unit		Narrow Profile Gully Unit	
Pros	Cons	Pros	Cons	Pros	Cons	Pros	Cons
Widely used drainage solution	Susceptible to blockage by leaves and debris	Widely used drainage solution	Less efficient solution	This split system reduces the risk of water ponding as the kerb inlet allows the capture of runoff even if the grating is blocked	Less commonly used drainage solution	Gully design, with very high efficiency	Less commonly used drainage solution
Less expensive capital costs	Location within the carriageway. Leading to potential maintenance issue	Simple hinged mechanism to allow for routine maintenance	More expensive capital cost due to requirements for non-standard units	Easier maintenance requirement during a storm event	Slightly more expensive capital costs	Simple hinged mechanism to allow for routine maintenance	
Maintenance requirements are well understood by operators	Settlement around gullies could lead to poor ride quality	Maintenance requirements are well understood by operators	Susceptible to blockage by leaves and debris	Simple dual hinged mechanism to allow for routine maintenance		Maintenance requirements are well understood by operators	
	Higher maintenance requirement during a storm event	Settlement around gullies is lesser as the system is outside the wheel track, thus improving ride quality		Settlement around gullies is lesser as the system is outside the wheel track, thus improving ride quality		Settlement around gullies is lesser as the system is outside the wheel track, thus improving ride quality	

A.1 Proposed Drainage Detail

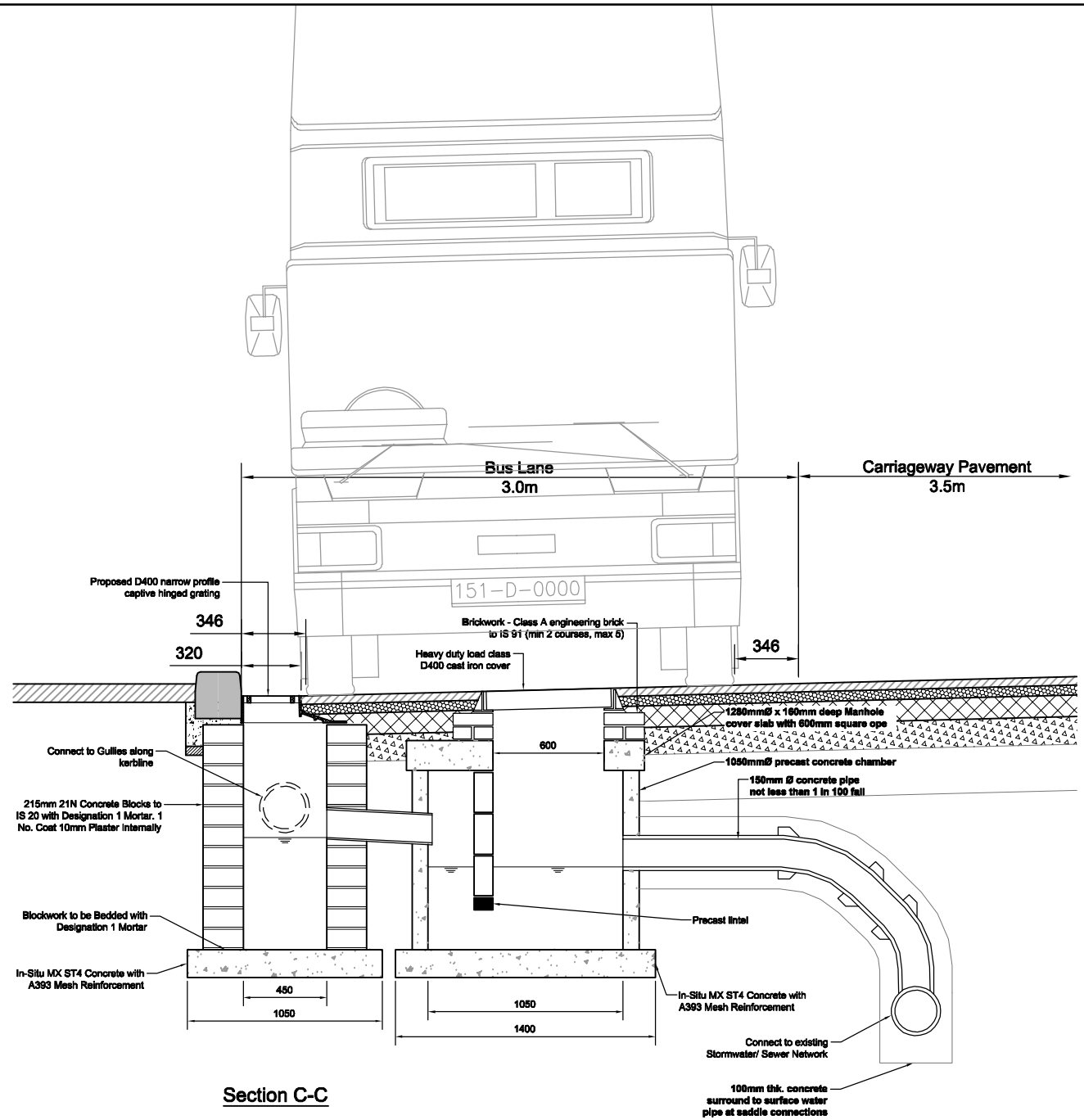
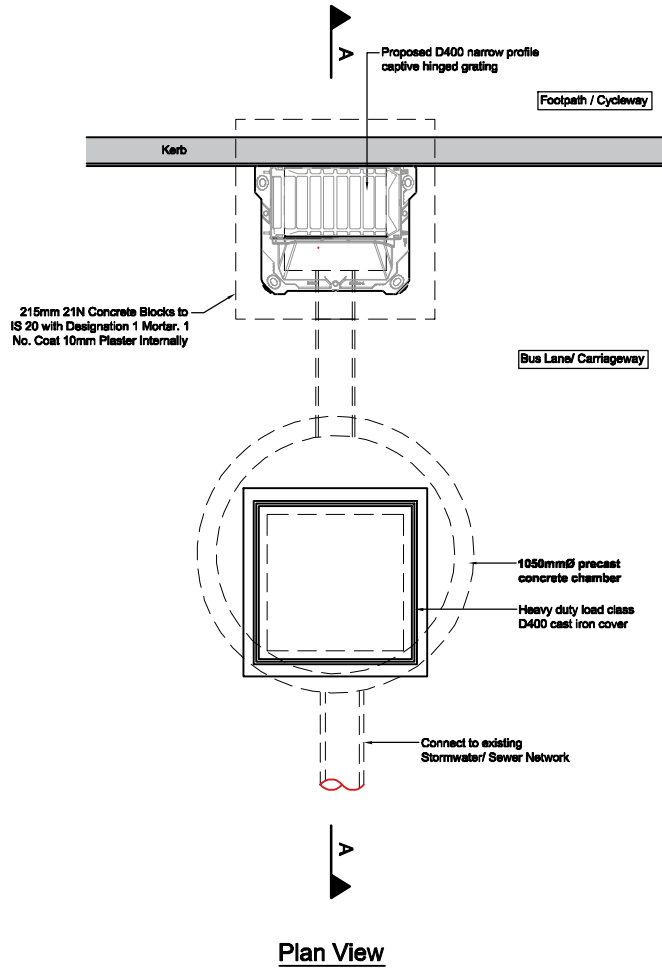

Typical Narrow Profile Gully and possible layout of connection chamber for surface water run-off to existing Combined Drainage Network

A.2 Data Sheets – Proprietary Unit #4

Driving safety up and whole
life costs down

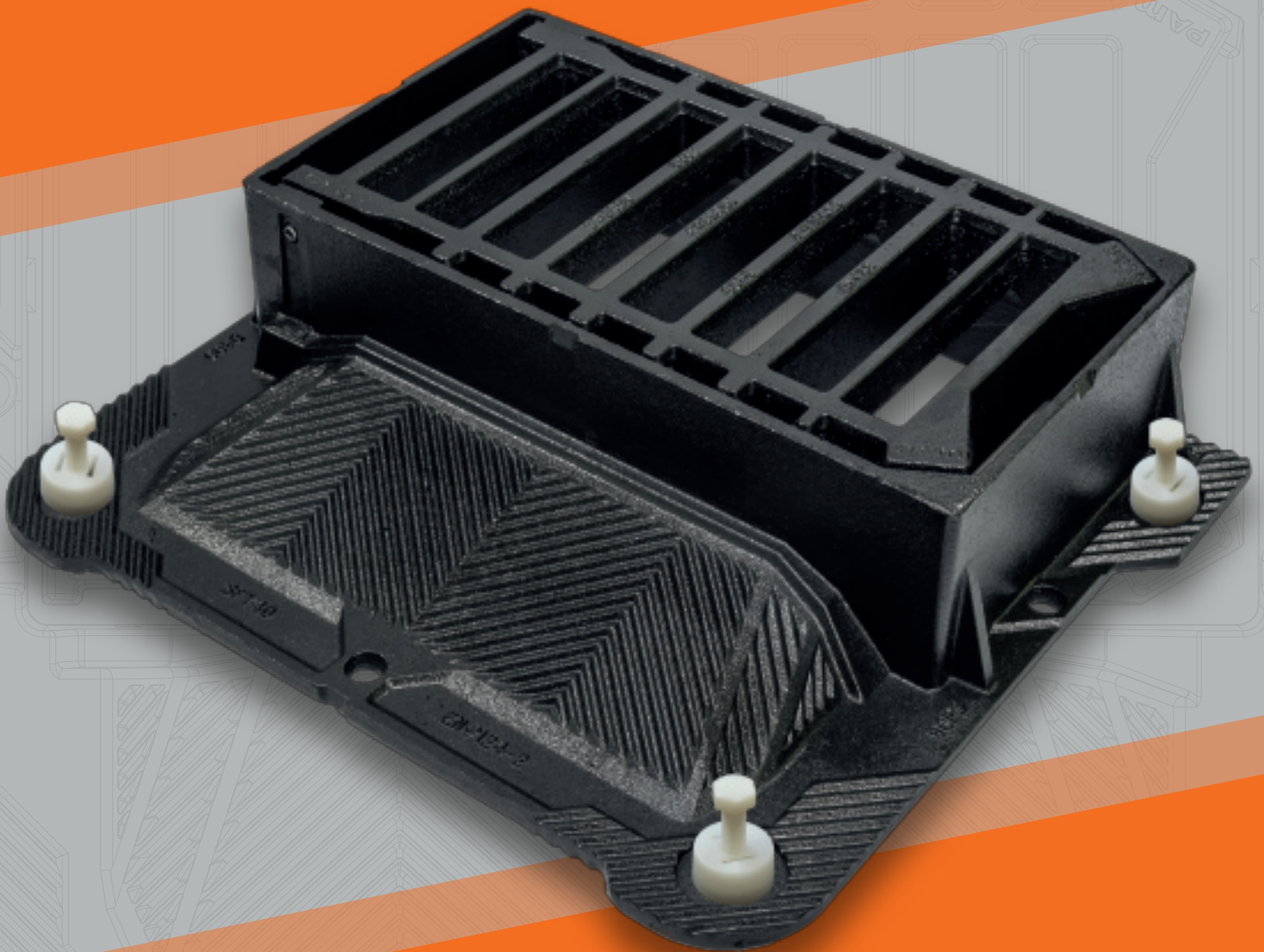

D400 Narrow Profile
Captive Hinged Grating

Proteus has been designed to offer an alternative solution in situations where regular replacement of traditional gratings occurs due to the units being directly in the wheel line, Proteus works by maintaining water absorbing capability at the kerb face whilst placing the portion of the unit usually in the wheel line below the road surface thereby making less susceptible to premature failure.

Proteus is manufactured in our UK foundry in Leicestershire to the highest safety, quality and manufacturing standards.

Safety

We have developed a solution in Proteus that offers safe and predictable grating operation. The grating section is hinged and opens to 110° ensuring the opening and closing sequence is safe, simple and predictable, reducing risk of injury. At 300mm wide the grating is designed to effectively remove storm water from the surface of the road whilst at the same time being out of the wheel track of all vehicles including bicycles.

Water Clearing Efficiency

The ability of a grating to effectively remove surface water is most important along the kerb line where 75% of water flows in typical rainfall conditions. Proteus has been designed to provide more than 2x the water clearing area along the kerb line when compared to a standard 450 x 450 mm grating.

Proteus has a Type R designation in accordance with Appendix A, Table A.2 Determination of grating type of Highways England Design Manual for Roads and Bridges CD 526 Spacing of road gullies.



	Water Clearing Area cm ²	
CD534 Section 2 paragraphs 2.14.2 & 2.14.3*	50 mm from kerbface	117.15
	90 mm from kerbface	231.14

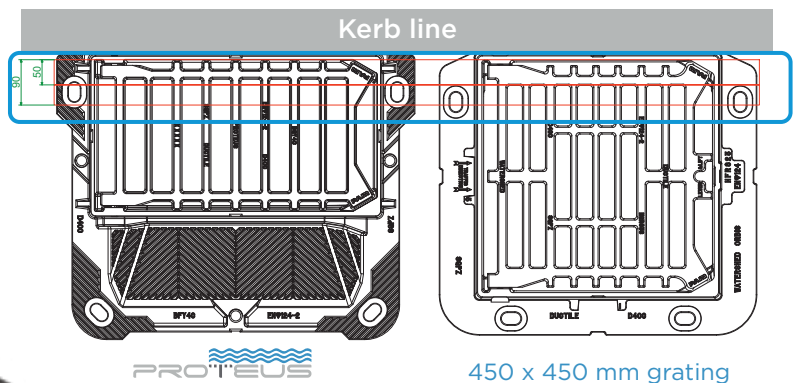

*Note: DMRB Volume 4 Section 2 Part 5 CD534 Section 2 Gully Tops paragraphs 2.14.2 & 2.14.3 state: *Of the total waterway area, there should be a minimum waterway area of 45 cm² between the kerb face of the frame and a parallel line 50 mm distant, and there should be a minimum waterway area of 65 cm² between the kerb face of the frame and a parallel line 90 mm distant.*

Durability

Its narrow grating profile avoids excessive clipping by traffic, its patented¹ angled bridge is designed to distribute stress and resist displacement resulting in a solution that offers long term performance while focusing on the reduction of whole life costs.

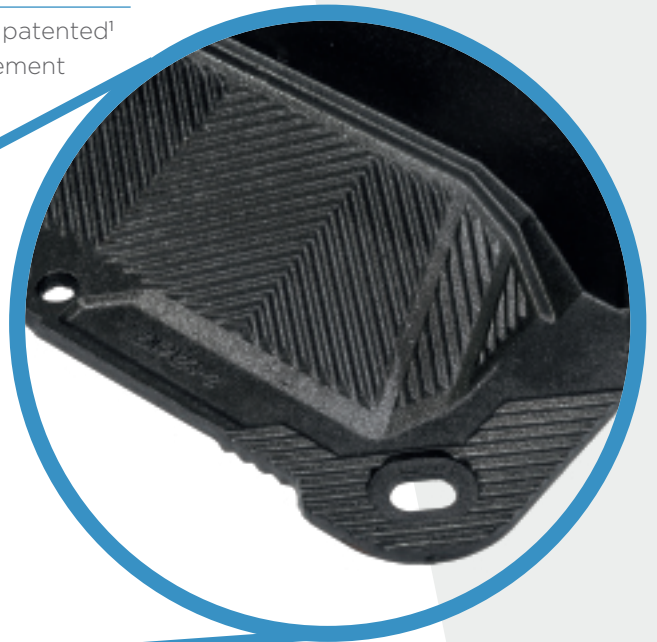

Multi-directional wedge seatings provide a large contact area between the grating and frame sections. This aids stability and resists lateral movement in the grating reducing wear, increasing longevity even under heavy traffic conditions.

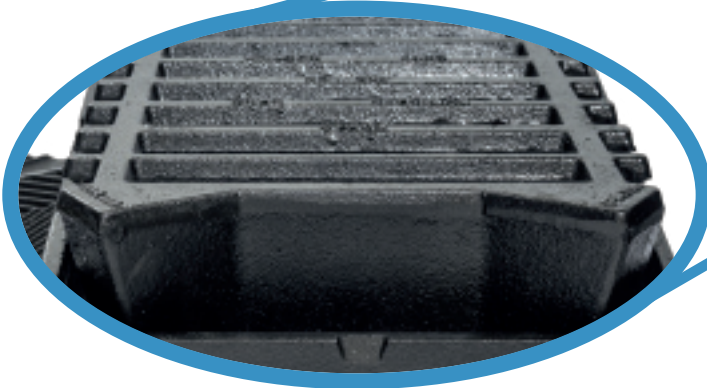
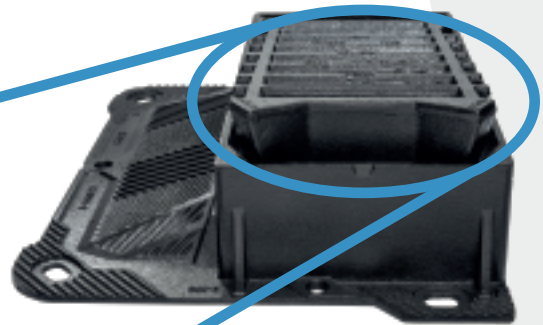

¹ UK IPO (Intellectual Property Office) Grant Number GB2580253



Compatibility

The longevity of any ironwork asset is directly linked to its alignment and compatibility with the structure below. It is vital that the dimensions of the frame match those of the opening of the chamber in ensuring the frame is fully supported. Through its unique design Proteus has a large footprint specifically designed to be compatible with any standard 450Ø gully pot making it an ideal replacement for any existing gully installation.

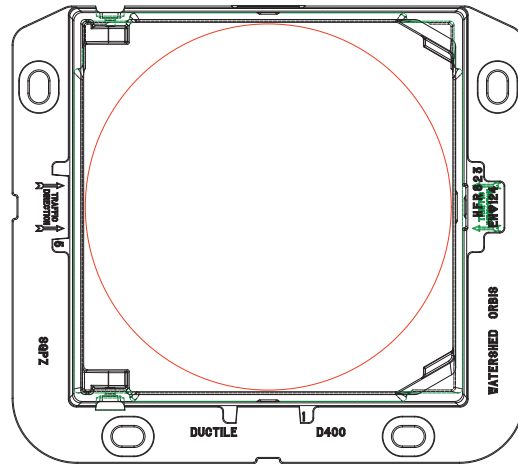
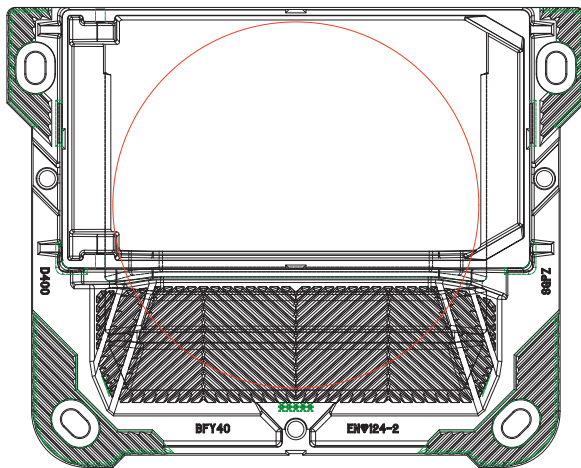

Watershed 450x450 mm

Performance & compliance

Proteus is manufactured from highly durable 500/7 grade ductile iron, which offers the optimum strength to weight ratio. It is designed, manufactured, inspected and tested in accordance with the stringent requirements of the European standard **BS EN124 2015 Pt 2**.

In addition, Proteus is fully compliant with the relevant requirements of sector specifications and design guidelines including

- **Highways England CD 534 Chamber tops and gully tops for road drainage and services.**
- **Highways England Section 507 Chambers and Section 508 Gullies & Pipe Connections of Series 500 Drainage and Service Ducts within Volume 1: Specification for Highway Works Manual of Contract Documents for Highway Works.**
- **BS7903: 2020 Selection and installation of manhole tops and gully tops within the highway – Guide.**
- **Highways England CD 526 Spacing of road gullies.**

Installation Guidance & Recommendations

It has long been acknowledged that the long term performance of any installation in the carriageway is directly attributed to the interaction and performance of all key components. Careful consideration should be given to:

- The design of the casting.
- The road type.
- The location and chamber type and its material whether concrete, brick, composite or plastic
- The method of installation and the quality of the materials used

To ensure optimum performance and durability we recommend installing Proteus using the **Rhino Asphalt Solutions Ltd; Ironmaster Installation and Reinstatement System**.

For further information please visit <https://www.rhino-uk.com/what-we-do/ironwork-rebuild-reinstate#proteus>



New Proteus Gully

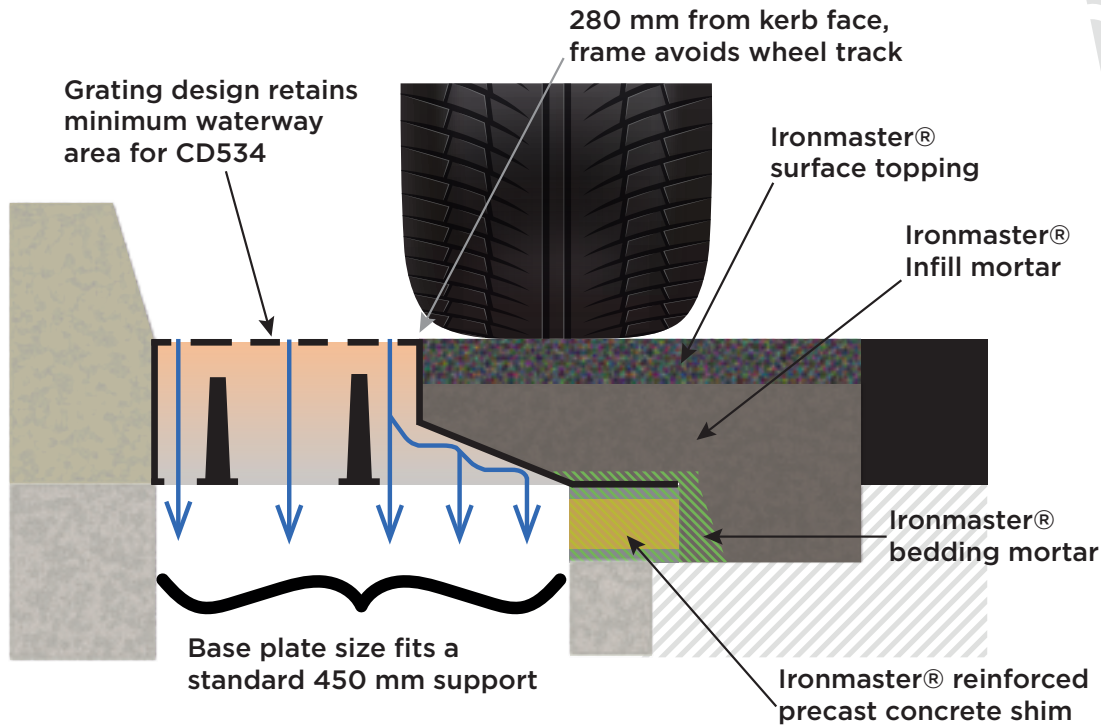

Where the Ironmaster system is not chosen we recommend the following process is adopted

Stage 1 - Preparation

Excavate ironwork

All existing reinstatement materials should be removed and the supporting structure/chamber cut back until a sound base is achieved. Trim back the surrounding surface in accordance with SROH which defines the trim back area as 'flange width of the frame + compactor sole plate width + 50 mm.

The newly-exposed substrate must be clean and structurally sound prior to commencing the installation.

Stage 2 - Positioning and adjusting the frame

Position the casting frame over the aperture of the gully pot ensuring it is central to the opening and the frame wall is supported on all sides. For optimum performance units are designed to be supported under the entire flange area, up to the edge of the clear opening. Failure to provide support over this area will have a detrimental effect to the long term performance of the unit.



To provide support and ease of adjustment in the early stages of installation, Proteus has the option of having the Install Plus Frame Levelling and Installation System added. To adjust the frame height and to also allow for changes in gradient, simply place a straight edge across the excavation and rotate the nylon bolts clockwise until the desired height is achieved. The bolts are sacrificial and have a range of movement between 15 mm and 50 mm.



Stage 3 - Bedding the frame

The depth of bedding materials needed to install the frame and cover level to the road surface is determined, taking into account the depth of the frame. It is recommended that a minimum depth of mortar below the flange is no less than 15 mm. Install Plus provides a spacer below the frame which is set to the minimum depth of 15 mm.

Stage 4 - Material Selection

For optimum durability the system has been designed to be used in conjunction with a high performance bedding material.

Bedding materials should be selected in accordance with the requirements of paragraphs 24,25 & 26 of Section 507 Chambers of 'Series 500 Drainage and Service Ducts Volume 1 Specification for Highway Works Manual of Contract Documents for Highway Works' and exhibit the following properties:

- Is cementitious and contains recycled materials.
- Have a minimum workable life of 15 minutes.
- The compressive strength of the material shall exceed 30N/mm² in 3 hours.
- The tensile strength of the material shall exceed 5N/mm² in 3 hours.



Stage 5 - Completing the installation

Voids below the flange must be completely filled with bedding material to ensure full support of the frame. Exposed surfaces of the bedding mortar around the frame are float finished and textured to create a key, ensuring any voids or loose material are removed and the inside surface pointed to a smooth finish.

The frame should be enveloped to a minimum thickness of 10 mm, however a minimum of 20 mm is recommended as this is viewed as industry best practice. The top cap of the Install Plus system gives a visual indication of when 20 mm has been achieved.



The bedding material must also extend beyond the flange to a minimum distance of 50 mm in accordance with SROH.

Stage 6 - Backfilling the excavation

Bedding material or rapid set concrete of the correct specification can be used to fill the excavation. All bedding materials shall be allowed to cure to a compressive strength exceeding $>30\text{N/mm}^2$ and tensile strength exceeding $>5\text{N/mm}^2$ before trafficking.



Stage 7 - Final reinstatement

Complete the reinstatement in accordance with client specification. If a material requiring compaction is used care must be taken to avoid contact between any compaction device and the frame to avoid damage.

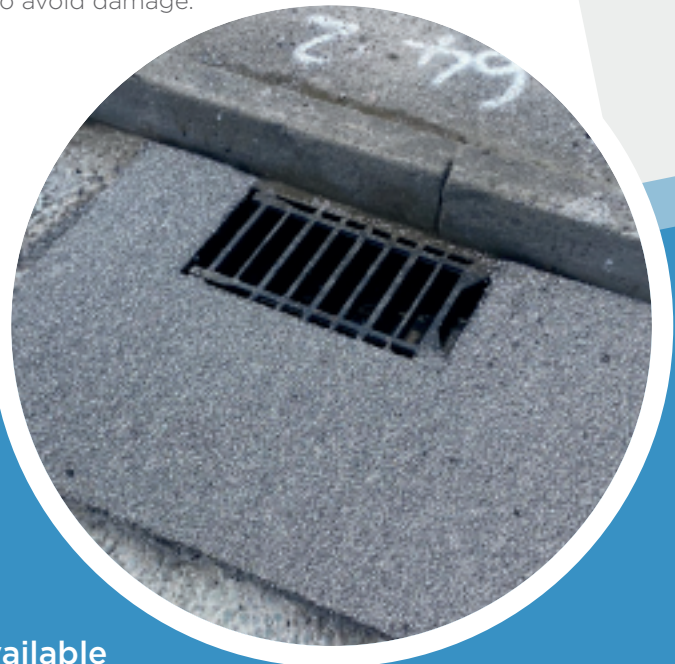

For further information please refer to product datasheet Ref SGPUK041, available to download from PAMSearch via our website or contact our Technical Support Team on 01664 814014



Please visit our website:

www.pamline.co.uk
to download electronic versions
or to request hard copies of any
of our brochures.

Technical Enquiries

Tel: +44 (0)1664 814014
Fax: +44 (0)1664 814025
Email: technical.covers.uk.pam@saint-gobain.com

Sales Enquiries

Tel: +44 (0)115 989 8903
Email: pamsales@saint-gobain.com

Head Office

Lows Lane
Stanton-by-Dale
Ilkeston
Derbyshire
DE7 4QU

Tel: +44 (0)115 930 5000
Fax: +44 (0)115 932 9513



FM12908



EMS83973



visit: www.pamline.co.uk

The information given in this literature is, to the best of our knowledge, correct at the time of going to print. However, Saint-Gobain PAM UK is constantly looking at ways of improving its products and services and therefore reserves the right to change, without prior notice, any of the data contained in this publication. Any orders placed will be subject to our Standard Conditions of Sale, available on request.

© 2020 Saint-Gobain PAM UK.

We are proud of our UK manufacturing heritage

Saint-Gobain PAM UK, at its foundry near Melton Mowbray in Leicestershire, remains at the forefront of the design and manufacturing of high-performance ductile iron access cover and grating solutions for the Infrastructure, Civil Engineering, Water & Utilities Sectors.



We ensure that our products are manufactured to the highest health & safety, quality and environmental standards. Below are details of our System, Product and Sustainability accreditation.

SYSTEM, PRODUCT AND SUSTAINABILITY ACCREDITATION

Product Certification	BS EN124 2015 Pt 2 Access Covers and gratings kitemark licence number KM30794
	BS 5834 Pt 2 Specification for small surface boxes kitemark licence number KM07199
	BS 5843 Pt 3 Specification for large surface boxes kitemark licence number KM14164
BS EN ISO 9001	Quality management systems kitemark licence number FM12908
BS EN ISO 14001	Environmental management systems kitemark licence number EMS83973
ISO 45001	Health & Safety Management Systems kitemark licence number OHS 570684
CEMARS	Certified Emissions Measurement And Reduction Scheme Certificate number 2016053J
	CEMARS certification demonstrates the Company's commitment to measuring, managing and reducing greenhouse gas emissions in a robust and credible way.
BES 6001	Responsible sourcing of construction materials kitemark licence number BES613621

D400 Narrow Profile Captive Hinged Grating

Proteus includes several features that enhance durability, security, ease of use and water clearing efficiency.

Its narrow grating profile avoids excessive clipping by traffic, its angled bridge is designed to distribute stress and resist movement resulting in a solution that offers long term performance while focusing on the reduction of whole life costs.

Its large footprint makes it compatible with any standard 450mm diameter gully pot.



DURABILITY

To aid the reduction of whole life costs, the Proteus design incorporates the Load Transfer System (LTS) to radically improve installation and product lifespan lowering the frequency of reinstatement.



SECURITY

A Captive hinged grating and an integral automatic spring bar locking mechanism combine to offer enhanced anti-theft and security capabilities.



HEALTH & SAFETY

To help reduce work-related injuries, an ergonomic hinged design makes opening simpler, easier and safer.



PERFORMANCE

The unit is non rock and silent in operation. Large multi-directional wedge seatings enhance stability and durability which reduces whole life costs.



ACCREDITATION

Third party certified by BSI and kite marked to the requirements of BS EN 124. Compliant to the requirements of Highways England advice note CD534.



WATER CLEARING EFFICIENCY

A special asymmetrical design in the area adjacent to the kerb disrupts the normal flow to increase the volume of water entering the gully.



SAVE TIME & COST

Available with the Instal Plus frame levelling and installation system as standard.

PROTEUS NARROW PROFILE D400 CAPTIVE HINGED GRATING RANGE	ISSUE NO:1	SGPUK041	DATE:	03.2020
Manufactured in the UK to the highest Quality, Environmental and Health & Safety Standards.				

PRODUCT DATASHEET

RECOMMENDED FOR USE IN:

Carriageways carrying continuous heavy traffic in areas requiring efficient removal of surface water

PROTEUS D400 NARROW PROFILE CAPTIVE HINGE GRATING RANGE

SAP Code	SAP Code with Install Plus	Opening Direction	BS EN124 Class	Clear Opening AxB (mm)	Grating Opening (mm)	Over Base C x D (mm)	Depth E (mm)	Waterway Area (cm ²)	CD526 Grating Ref.	Total Mass (kg)	Pallet Quantity
270993	TBC	Left Hand	D400	455 x 455	300 x 560	711 x 565	150	997	R	67.5	12
278237	TBC	Right Hand	D400	455 x 455	300 x 560	711 x 565	150	997	R	67.5	12

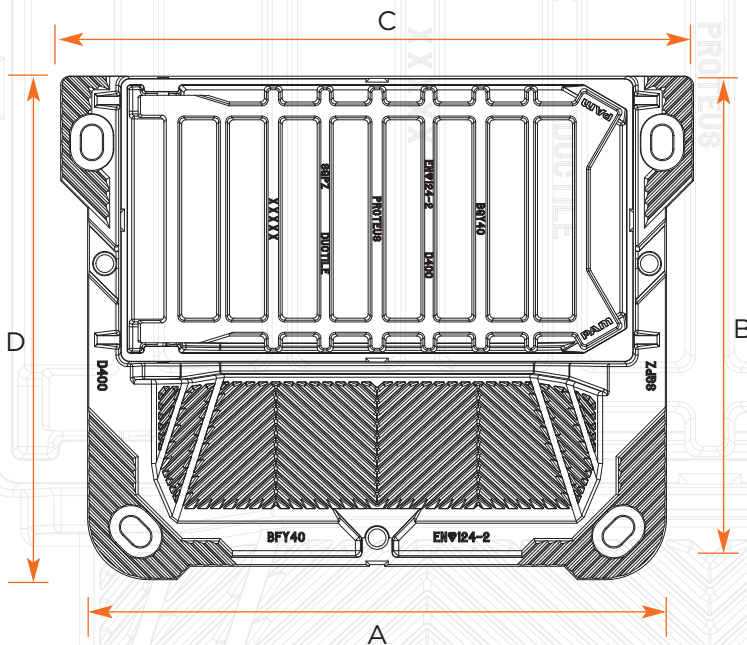

	WATER CLEANING AREA CM ²	
CD534 section 2 paragraphs 2.14.2 & 2.14.3*	50mm from kerbface	117.15
	90mm from kerbface	231.14

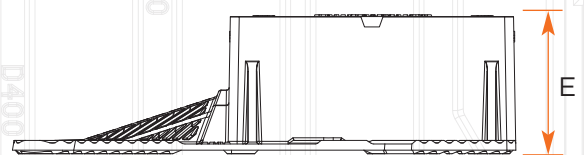

Overbase footprint comparison overlaid on a 450mm diameter gully pot

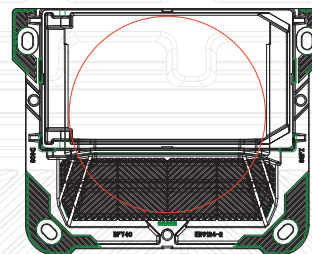

Proteus

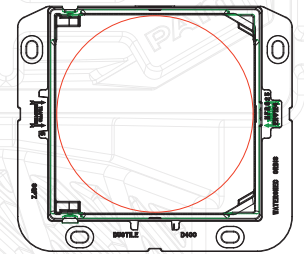

Watershed 450x450mm

Notes

*CD534 Section 2 paragraphs 2.14.2 & 2.14.3 states 'of the total waterway area, there should be a minimum waterway area of 45cm² between the kerb face of the frame and a parallel line 50mm distant, and there should be a minimum waterway area of 65cm² between the kerb face of the frame and a parallel line 90mm distant.'

Grating and frame components are coated in a VOC free water based cationic bituminous emulsion that when dried is classified as non-hazardous and non-toxic.

The information on this sketch is, to the best of our knowledge correct at the time of printing. However, Saint-Gobain are constantly looking at ways of improving their products and services therefore reserve the right to change without prior notice, any of the data shown. Any orders placed will be subject to our Standard Conditions of Sale, available on request.

COPYRIGHT AND DESIGN RIGHT

This drawing is the exclusive property of Saint-Gobain PAM UK and is confidential and must not be reproduced or disclosed for any third party without written consent. It must be used only for the purpose for which it has been issued and is returnable on request.